



Instruction Manual

CE DOCUMENT EST GRATUIT

ET NE PEUT

EN AUCUN CAS

ÊTRE VENDU

Models

A7 500 c.c. O.H.V. Twin

A7 500 c.c. O.H.V. Shooting Star

A10 650 c.c. O.H.V. Golden Flash

A10 650 c.c. O.H.V. Super Rocket

AVANCE - longueur 9,5 = 32^e

Instruction Manual

for

 **BSA**

A Models

CE DOCUMENT EST GRATUIT

ET NE PEUT

EN AUCUN CAS

ÊTRE VENDU

B.S.A. MOTOR CYCLES LTD., BIRMINGHAM 11

Telephones: Birmingham VICToria 2381

Telegrams and Cables: "SELMOTO", Birmingham.

Service, Spares and Repairs Department

WAVERLEY WORKS, BIRMINGHAM 10

Telephones: Birmingham, VICToria 3712

Telegrams and Cables: "SELSERV", Birmingham.

B.S.A. Motor Cycles Ltd. reserve the right to alter the designs or any constructional details of their manufactures at any time without giving notice.

Printed in England.

MC.1048-5-10

Copyright B.S.A. Co. Ltd.

Reprinted Nov., 1959

This Instruction Manual is intended to acquaint the B.S.A. owner with details of the controls, general maintenance and technical data which may be required for normal operation of the machine.

It does not contain the information necessary to carry out complete stripping for major overhauls, but if any owner feels he is competent to carry out this type of work a Service Manual and an illustrated, priced, Spares Catalogue for this machine can be obtained from your B.S.A. spares stockist or local distributor.

Owners in the British Isles can obtain these publications direct from B.S.A. Motor Cycles Ltd., Service Dept., Waverley Works, Birmingham 10. The Service Manual is priced at six shillings and sixpence, plus sixpence postage, and the Spares Catalogue is five shillings and sixpence, plus sixpence postage. Always quote full engine and frame numbers when ordering these publications.

CONTENTS

	Page
BATTERY	45
BRAKES	34
CARBURETTER	24
CHAINS	28/37
CLEANING	11
CLUTCH	30
CONTROLS	6
DATA	4/5
DECARBONISING	20
DYNAMO	46
ELECTRICAL EQUIPMENT	45
ENGINE LUBRICATION	11
FORKS	40
GEARBOX	32
HUBS	34
IGNITION TIMING	16
MAGNETO	48
PISTON AND RINGS	23
PRIMARY CHAINCASE	30
REAR SUSPENSION	43
RUNNING-IN	10
SPARES STOCKISTS	53
SPARKING PLUGS	14
STEERING HEAD	40
TRANSMISSION	28
VALVE CLEARANCES	13
VALVE TIMING	18
WHEELS	34
WIRING DIAGRAM (A.7, A.7S.S., A.10G.F.)	48, 49
WIRING DIAGRAM (A.10 Super Rocket)	50, 51

$5 \frac{1}{4} = 3 \text{ l} -$
 $1 \text{ l} \frac{3}{4} =$

		TECHNICAL	
		A.7	
Réservoir	Petrol tank capacity galls.	2 or 4	
motocycle	Oil tank capacity pints	5 1/2	
B. Vitesse	Gearbox capacity fl. oz.	14 (400 c.c.)	
roue	Front Fork capacity BSA .. fl. oz.	7 1/2 (213 c.c.)	Triumph
Ch. Prim.	Primary chain oil bath fl. oz.	8 (225 c.c.)	
	Bore (m.m.)	66	
	Stroke (m.m.)	72.6	
capacité	Capacity (c.c.) cm ³ cylindres	497	
Soupape	Valve clearance (cold) inlet admission	.008"	
 exhaust échappement	.010"	
taux compression	Compression ratio	7.25-1	
	Piston ring gap maximum	.013"	
 minimum	.009"	
	Valve timing inlet ouvert opens b.t.d.c.	42°	
	.. fermé closes a.b.d.c.	62°	
	exhaust ouvert opens b.b.d.c.	67°	
	.. fermé closes a.t.d.c.	37°	
	Contact breaker gap012"	
	Ignition timing—piston distance b.t.d.c. with points just opening avancée ..	1/8" (7.9 m.m.)	
	Spark plug	*L7	
	Plug points gap maximum	.020"	
 minimum	.018"	
ecartements du	Gear ratios Top	Solo 5.28 : S'car 5.9	
	Third	6.28 : 7.02	
	Second	9.28 : 10.35	
	First	13.62 : 15.2	
	Clutch friction plates	5	
	Tyre size front	3.25-19	
 rear	3.50-19	
	Tyre pressure (p.s.i.) front	17	
 rear	19	
	Wheel rims	WM2-19	
	Chain size and pitches: front	68	primaire
Secondaire rear	98	secondaire
	Teeth on rear chainwheel	Solo 42 : S'car 42	
	engine sprocket	18 : 18	
	clutch sprocket	43 : 43	
	gearbox sprocket	19 : 17	
	Total front fork movement	5 1/2" (14.6 c.m.)	
	Total rear suspension movement	4" (10.2 c.m.)	
	Brake dimension front	7" x 1 1/2"	
 rear	7" x 1 1/2"	
	Carburettor bore	1 1/8"	
	main jet	210	
	pilot jet	25	
	throttle valve	376/3 1/2	
	needle position	2	
	needle jet1065	
Air Cleaner	C & W	

		DATA	
		A7 S.S.	
	2 or 4		
	5 1/2		
	14 (400 c.c.)		
	7 1/2 (213 c.c.)		
	8 (225 c.c.)		
	66		
	72.6		
	497		
	.008"		
	.010"		
	8.0-1		
	.013"		
	.009"		
	42°		
	62°		
	67°		
	37°		
	.012"		
	1/8" (9.5 m.m.)		
	N3		
	.020"		
	.018"		
	Solo 5.28 : S'car 5.9		
	6.38 : 7.02		
	9.28 : 10.35		
	13.62 : 15.2		
	5		
	3.25-19		
	3.50-19		
	17		
	19		
	WM2-19		
	68		
	98		
	Solo 42 : S'car 42		
	18 : 18		
	43 : 43		
	19 : 17		
	5 1/2" (14.6 c.m.)		
	4" (10.2 c.m.)		
	8" x 1 1/2"		
	7" x 1 1/2"		
	1"		
	270		
	30		
	376/3 1/2		
	3		
	.1065		
	Vokes (if fitted)		
	2 or 4		
	5 1/2		
	14 (400 c.c.)		
	7 1/2 (213 c.c.)		
	8 (225 c.c.)		
	70		
	84		
	646		
	.008"		
	.010"		
	7.25-1		
	.013"		
	.009"		
	42°		
	62°		
	67°		
	37°		
	.012"		
	1/8" (10.6 m.m.)		
	L7		
	.020"		
	.018"		
	Solo 4.53 : S'car 5.28		
	5.48 : 6.28		
	7.96 : 9.28		
	11.68 : 13.62		
	5		
	3.25-19		
	3.50-19		
	17		
	19		
	WM2-19		
	68		
	98		
	Solo 42 : S'car 42		
	21 : 18		
	43 : 43		
	19 : 19		
	5 1/2" (14.6 c.m.)		
	4" (10.2 c.m.)		
	8" x 1 1/2"		
	7" x 1 1/2"		
	1 1/8"		
	420		
	25		
	389/3		
	2		
	.106		
	C & W		

19 cl.
 200 cm³

A10 S.R. 9 l ou 18 l
 2 or 4
 5 1/2
 14 (400 c.c.)
 7 1/2 (213 c.c.)
 8 (225 c.c.)
 70
 84
 646
 .008" 0,20 in/m
 .010" 0,25 in/m

0,30 in/m
 1/8" (10.6 m.m.)
 L7
 .020"
 .018"
 Solo 4.53 : S'car 5.28
 5.48 : 6.28
 7.96 : 9.28
 11.68 : 13.62
 5
 3.25-19
 3.50-19
 17
 19
 WM2-19
 68
 98
 Solo 42 : S'car 42
 21 : 18
 43 : 43
 19 : 19
 5 1/2" (14.6 c.m.)
 4" (10.2 c.m.)
 8" x 1 1/2"
 7" x 1 1/2"
 1 1/8"
 420
 25
 389/3
 2
 .106
 C & W

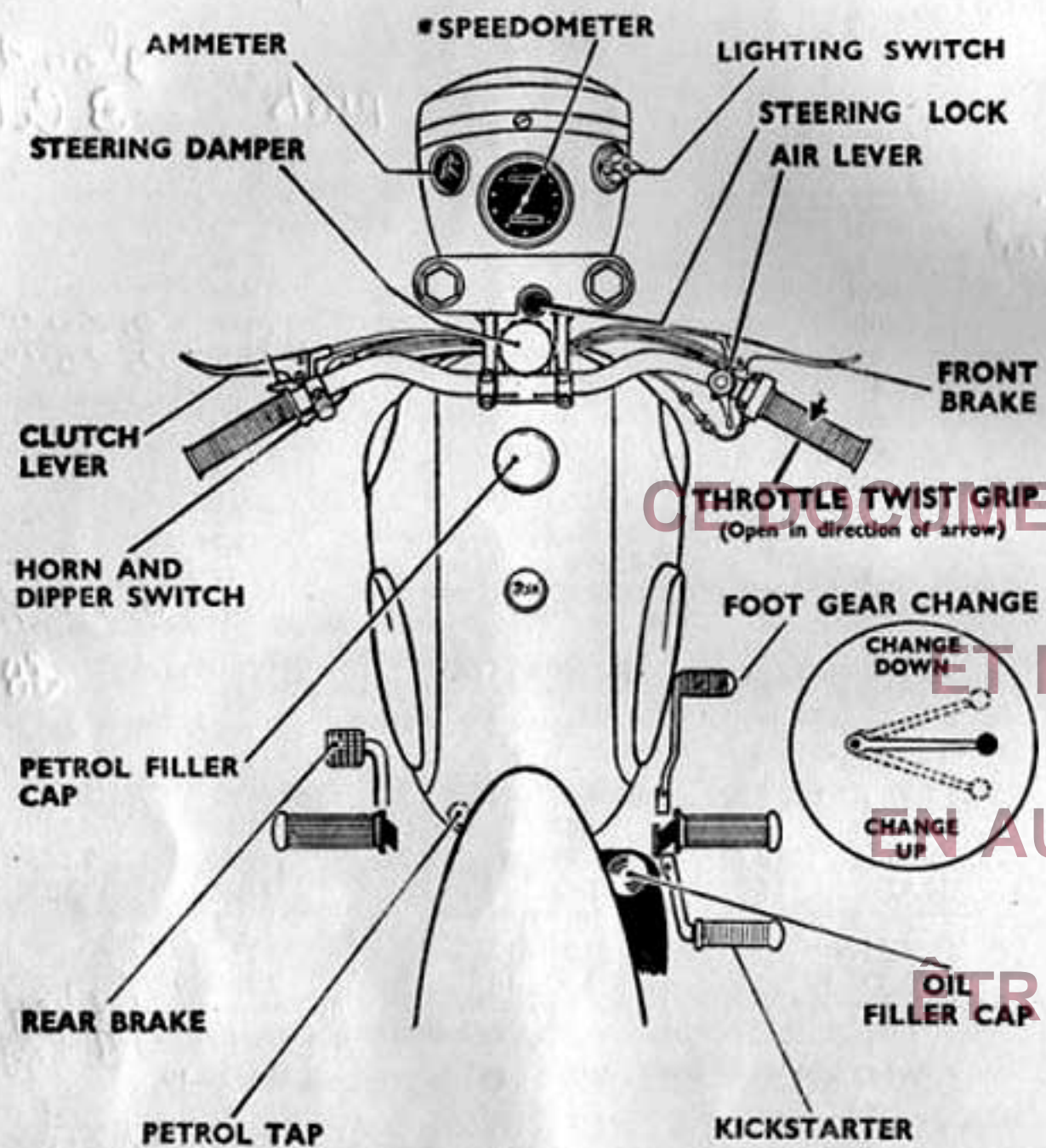

Fig. 1 The Controls

TAKING OVER THE MACHINE

Before running the machine make sure that the oil tank, gearbox, primary chain case and front forks are properly topped up with oil and that the battery is filled and charged. (See appropriate chapters for filling instructions.) Normally these preparations will be carried out by the dealer who is selling the machine and the new owner has only to arrange the controls to his liking and the machine is ready for the road.

The Controls.

The new rider should make sure that he is quite familiar with all the controls before attempting to ride the machine. Most of the controls are adjustable and should be positioned so that they can be reached without moving the hands

from the grips or the feet from the footrests. Handlebars and footrests should be adjusted so that a comfortable and natural riding position is achieved. Make sure that the bolts retaining the handlebar clamps are tight after completing any adjustment. Badly positioned controls cause poor control of the machine and will bring discomfort on long journeys.

Handlebar Controls.

Twist Grip.

Mounted on the right handlebar, it controls the throttle opening. To open the throttle (i.e. to increase engine speed) turn the grip so that the top moves towards the rider. Full movement is about half a turn.

Front Brake.

Hand lever mounted on the right handlebar in front of the twist grip. Squeeze the lever towards the bar to operate the brake.

Clutch.

Hand lever mounted on the left handlebar in front of the grip. Squeeze the lever towards the bar to free the clutch, i.e. disengage the drive between the engine and the rear wheel.

Air Lever.

Mounted on the right handlebar attached to the rear of the brake lever. It controls an air valve in the carburetter by means of a bowden cable. The air valve should be closed when starting with the engine cold.

Ignition Lever. (A7 Shooting Star, A10 Super Rocket.)

Mounted on top of the left handlebar and controls the amount of ignition advance and retard.

Ignition Cut-out.

The control button is situated in the centre of the handlebars. Pressure on this for a second stops the engine.

Horn.

The horn button is mounted on the left handlebar in a combined mounting with the headlamp dipper switch.

Headlamp Dipper Switch.

On the left handlebar attached to the rear of the clutch lever. It controls the switching from main to dipped headlamp bulb filaments.

Foot Controls.

Rear Brake Pedal.

On the left hand side of the machine and controls the rear brake only.

Gearchange Pedal.

On the right hand side of the machine and effects the change from one gear to another. The lever is of the positive stop type and returns to the central position after each change. Upward movement of the lever selects the next lower gear, downward a higher gear. Neutral is between first and second gear.

Kickstarter.

The kickstarter is on the right hand side of the machine behind the footrest. Depression of the lever rotates the engine.

Other Controls.

Petrol Taps.

These are located under the rear end of the tank. To turn the petrol on, pull the button out and lock in position by turning anti-clockwise. To turn the petrol off, reverse the procedure. Both taps communicate with the main supply in the tank, but if only one tap is used, a reserve is left in the tank which can only be fed to the carburetter when the second tap is turned on.

***Lighting Switch.**

Mounted on the left of the headlamp cowl and has three positions, OFF—all lights off but dynamo charging when the engine is running. L—pilot bulb, rear lamp and speedometer bulbs illuminated. H—headlamp bulb, rear lamp and speedometer bulbs illuminated and the switching from main to dipped beam controlled by the dip switch.

***Ammeter.**

Mounted on the right of the headlamp cowl and indicates the rate at which current flows into or out of the battery.

***Speedometer.**

Set in the centre of the headlamp cowl. The trip mileage recorder can be turned back to zero by pulling out the spring loaded flexible control under the cowl and turning it in a clockwise direction.

Steering Damper.

Situated above the steering column at the centre of the handlebars. Tightening down the knob increases the friction damping. The damper should only be used for high speed solo riding.

Carburetter Tickler.

This is a small plunger in the top of the carburetter float chamber. Pressing it down pushes down the float and frees the needle valve thus permitting the carburetter to receive excess petrol.

Steering Lock.

Mounted in the top fork yoke. To operate the lock turn the forks to the left, then turn the key in the lock to release the plunger. This prevents the machine being driven or wheeled away.

• These components are centrally mounted in a panel on top of the headlamp on the Super Rocket.

To Start the Engine.

Stand astride the machine. Make sure that the gearbox is in neutral, i.e. between first and second gear. If the machine is in gear it will move forward as the kickstarter is pushed down.

If the engine is cold, first depress the carburetter tickler momentarily. (Retard the ignition slightly on Shooting Star and Super Rocket models.) Close the air lever, open the twist grip a small amount, and give the kickstarter pedal a vigorous kick downwards.

Note that while it is necessary to close the air lever when starting from cold, this may not be necessary when the engine is warm, and should certainly not be so if a restart is made after a short wait only. On some occasions, such as when the engine is not fully warmed up, or when it has cooled down a little during a temporary halt, for instance, it may require the air lever to be partly closed for starting, and the rider is advised to study this point.

During normal running the air lever should always be kept fully open, and the ignition lever advanced as far as possible on the Shooting Star and the Super Rocket models, although a slight gain in power at low speeds on hills may sometimes be obtained if both levers are eased back a very small amount.

To Engage First Gear.

With the engine idling slowly disengage the clutch by pulling in the handlebar lever and, after a moment, lift the gear lever as far as it will go so that first gear is selected. If the lever will not move through its full travel and the gear does not engage, move the machine backwards and forwards slightly maintaining a light pressure on the lever until the gear is felt to engage.

Open the throttle slightly and gently release the clutch lever until the clutch can be felt to take up the drive. Open the throttle a little more and very slowly release the clutch as the machine moves away. Do not rev the engine excessively or allow the clutch to slip for longer than is necessary to get the machine away in first gear.

To Change Gear. (Up.)

Close the throttle, disengage the clutch and press the gearchange pedal downwards as far as it will go. All these operations should be performed simultaneously. Immediately after changing gear, re-open the throttle and re-engage the clutch. Violent pressure on the gear lever is not desirable and a smooth firm movement of the pedal is most effective. After a little practice, smooth and quiet gearchanges will be possible at all times.

To Change Gear. (Down.)

Open the throttle slightly, disengage the clutch and draw the gearchange lever upwards to its limit, all these operations being performed simultaneously. Return the throttle to its original position and re-engage the clutch as soon as the gear change has been completed.

To Select Neutral.

Neutral is situated between first and second gear. To select neutral from first gear, with the clutch withdrawn push the gearchange pedal down gently until it is felt to click into position. If the lever is pushed down too far it will travel through to second gear. To select neutral from second gear, pull the lever up until it is felt to click into position.

Riding Hints.

Avoid violent acceleration and braking, particularly on wet roads. Always use both brakes together and apply them smoothly and progressively. Try to anticipate the need to change gear or brake, so that your riding is not jerky or untidy. Maintain a natural riding position as this provides maximum control and prevents discomfort on long journeys.

Running In.

The rider who has just purchased a new machine will do well to remember that all the internal parts are just as new as the enamel and plating which can be seen, and they must be well 'run-in' before the engine can be given any really hard work.

The 'running-in' process is the most important period in the life of the engine, and the handling it receives during the first 1,000 to 1,500 miles will determine the service it will provide in return.

It is advisable not to exceed one third throttle in any gear during the early stages. If excessive speeds are used there is the risk of piston seizure and other troubles, and in any event until the machine has been 'run-in' it cannot be expected to give its best performance. In particular, avoid rapid acceleration, and do not allow the engine to labour on hills in a high gear when a change to a lower gear would ease the load.

As the mileage builds up the permitted throttle opening may be increased until, when the 'running-in' process has been completed, full throttle can be employed.

Do not let the oil level in the tank get too low, as economy in oil may prove very expensive at a later date. Running consistently with the oil level too low may cause the oil to become unduly hot. It must be remembered that the oil cools as well as lubricates, and a new engine tends to run a little hotter than one that is well 'run-in'. After the first 250 miles, drain and refill the oil tank with fresh oil and clean the filters. Repeat this process after 1,000 miles, and thereafter every 2,000 miles. The correct grades of oil are given in the lubrication chart. The oil in the gearbox should also be changed at 500 miles and further changes made every 2,000 miles.

During the 'running-in' period it is advisable to check the various adjustments such as tappet clearances, contact breaker gap, clutch adjustment, etc., rather more frequently than usual, and to check the tightness of all nuts and bolts to make sure that the initial bedding down does not loosen any components.

It is a good idea to add a small quantity of upper cylinder lubricant to the petrol each time the tank is replenished. If this is difficult to obtain, add about an eggcupful of engine oil to every two gallons of petrol.

Routine Maintenance.

To keep the machine in good condition and provide trouble-free running maintenance must be regularly carried out. The following list of items requiring regular attention will serve as a guide to the periods between servicing and the method of carrying out the various adjustments will be found under the appropriate headings in the later chapters.

Weekly.

Check tyre pressures and remove any embedded stones or pieces of metal.
Oil all exposed joints and cables.

Monthly.

Examine the battery and top up if necessary. More frequent examination is advisable in a hot climate.

Every 300 Miles. *500 kms*

Check oil levels in oil tank, gearbox and primary chaincase and top up if necessary.

250 miles = 400 kms.

Every 1,000 Miles. *1600 kms*

Grease steering head, clutch arm, central stand.
Grease brake cam spindles.
Check rear chain adjustment.

Every 2,000 Miles. *3200 kms*

Change the engine oil and clean the filters.
Change the oil in the gearbox.
Check primary chain adjustment.
Check tightness of all nuts and bolts.

Every 3,000 Miles. *4800 kms*

Check contact breaker adjustment and apply a few drops of light machine oil to the felt pad.

Cleaning.

Take care when cleaning the machine that dirt is not introduced into the carburetter, hubs, magneto, etc. Do not attempt to rub off dry dirt or mud as this will damage the enamel. Wash off any dry dirt with a copious supply of clean water, preferably from a hose. Any oily areas should be treated with a detergent before being hosed down. Dry the machine with a piece of clean rag and, if possible, clean it in a warm dry day so that all moisture is removed before polishing with a good wax polish. Exposed threads and controls which might suffer from rusting should receive a smear of oil to protect them.

Maintenance and Overhaul.

Whenever any work is carried out on the machine attention to detail and scrupulous cleanliness must be observed. All joints must be clean and gaskets in good condition before re-assembly. Threads must be kept clean and free from grit, and exposed threads should be oiled or greased before assembly. Good fitting spanners should be used at all times and nuts must be done up quite tight, but spanners of greater than standard length should not be employed as they may cause failure through overtightening.

ENGINE

Lubrication System.

The lubrication system is of the dry sump type and is operated by a double gear pump situated in the bottom of the timing case (see Fig. 3). The oil tank capacity is 5½ pints. Oil is drawn from the oil tank through the wire mesh filter as illustrated in Fig. 2, to the supply pump (smaller set of gears). It is then pumped past the non-return valve to the timing side main bearing and thence to the hollow crankshaft and the big end bearings, whilst a further oilway supplies oil via a pressure control valve to the timing gears and camshaft trough.

After lubricating the engine the oil drains down through a filter to the bottom of the crankcase, from which it is drawn by the return pump (larger set of gears), past the anti-syphon ball valve and delivered up the return pipe to the tank. At the junction of the return pipe with the tank a by-pass pipe leads a supply of oil to the rocker gear. The surplus oil from the rockers flows down the push rod tunnel back into the crankcase.

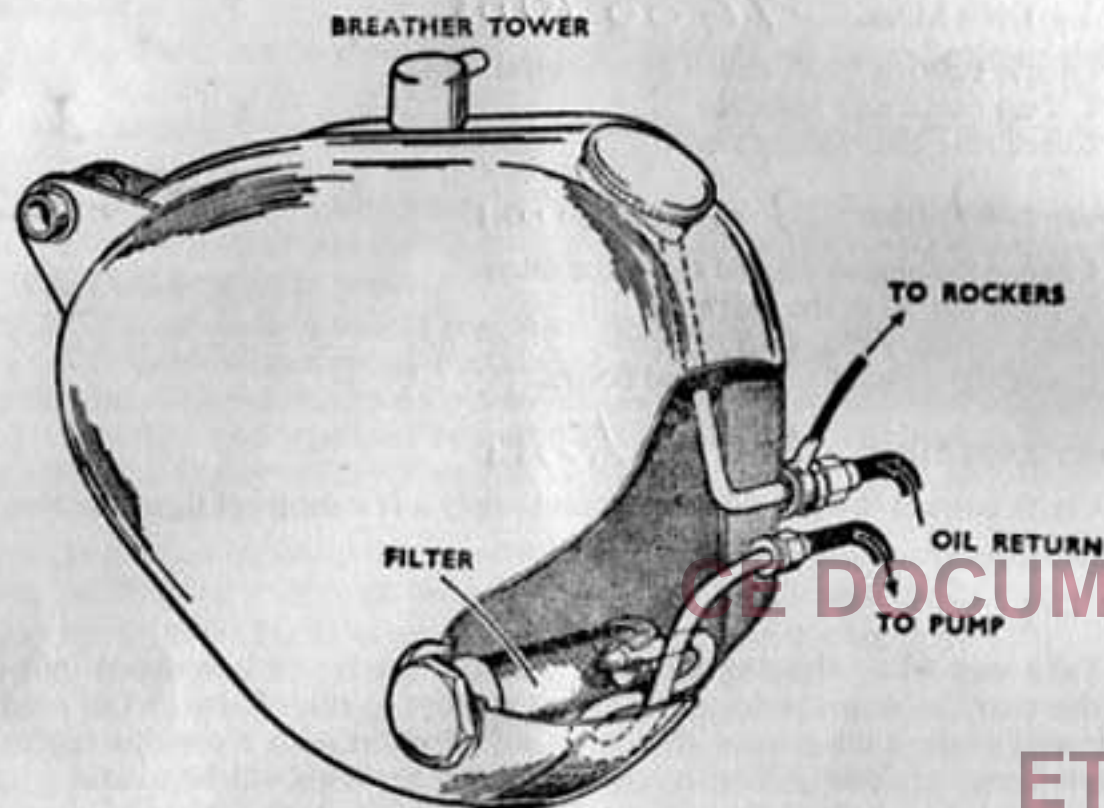

Fig. 2 The Oil Tank

If the ball valve A does not seat properly, the big ends may not receive an adequate supply of oil. Remove the valve periodically and thoroughly clean the ball and its seat. If the latter appears unsound, replace the ball on its seat and give it a sharp tap with a light hammer and a suitable punch to ensure that it has properly bedded down.

If the anti-syphon ball valve should get stuck in its seating, there will be no return of oil to the tank. To rectify this remove the cover plate, insert a piece of wire into the valve orifice, and lift the ball off its seating to free it. To check the flow of oil in the lubricating system, remove the tank filter cap whilst the engine is running. Oil should be seen issuing from the return pipe just inside the filler cap.

The oil tank filter is attached to the large chromium plated nut screwed into the outside of the oil tank. When the filter requires cleaning this nut should be unscrewed and the filter washed in petrol. Make sure that all the petrol has evaporated from the filter before replacing.

The pump filter can be withdrawn after removing the crankcase cover plate and should be thoroughly washed with petrol, dried and replaced. The oil pump is extremely reliable and it is most unlikely that it will give trouble, therefore it should not be disturbed unnecessarily. The pump is held in position by the two bolts with spring washers under their heads. The two other bolts hold the sections of the pump together.

Oil Changes.

The oil should be changed every 2,000 miles. To drain the oil, remove the filter in the side of the oil tank by unscrewing the large hexagonal cap. The oil remaining in the crankcase can be drained by removing the small hexagonal-headed drain plug or the crankcase bottom cover plate which is retained by four

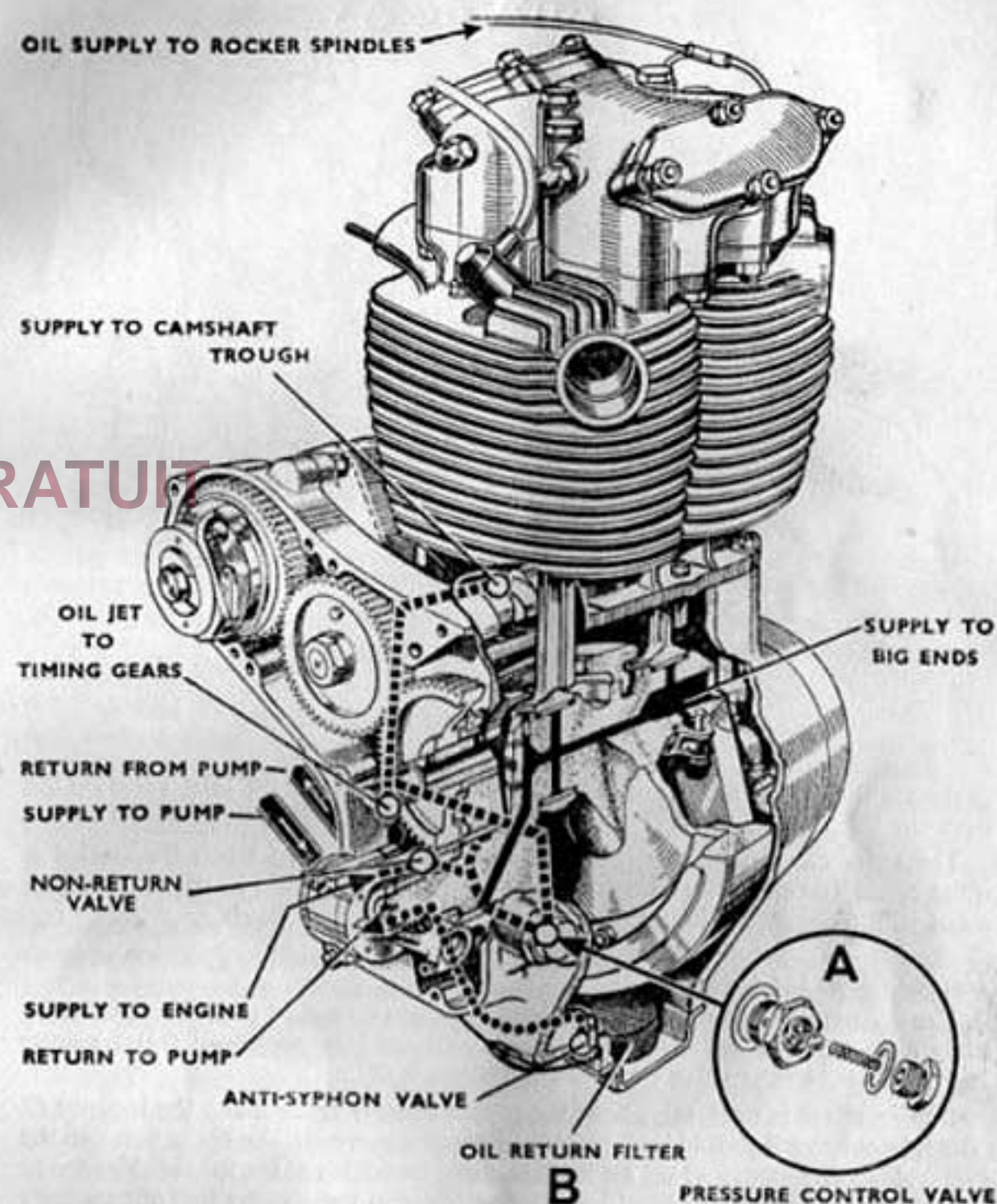

Fig. 3 Lubrication System.

studs. Removal of this cover plate allows access to the crankcase filter which can be withdrawn for cleaning. The filters should be washed thoroughly in petrol and allowed to dry completely before being replaced. When replacing filters make sure that they engage correctly with the feed pipes which pass through them. Whenever possible the oil should be drained when the engine is warm, as the oil will then flow more freely.

Valve Clearances.

Checking the Clearances.

Remove the tappet inspection covers A (Fig. 4,) and rotate the engine until one inlet valve is fully open. This is the correct position for checking the other inlet valve clearance.

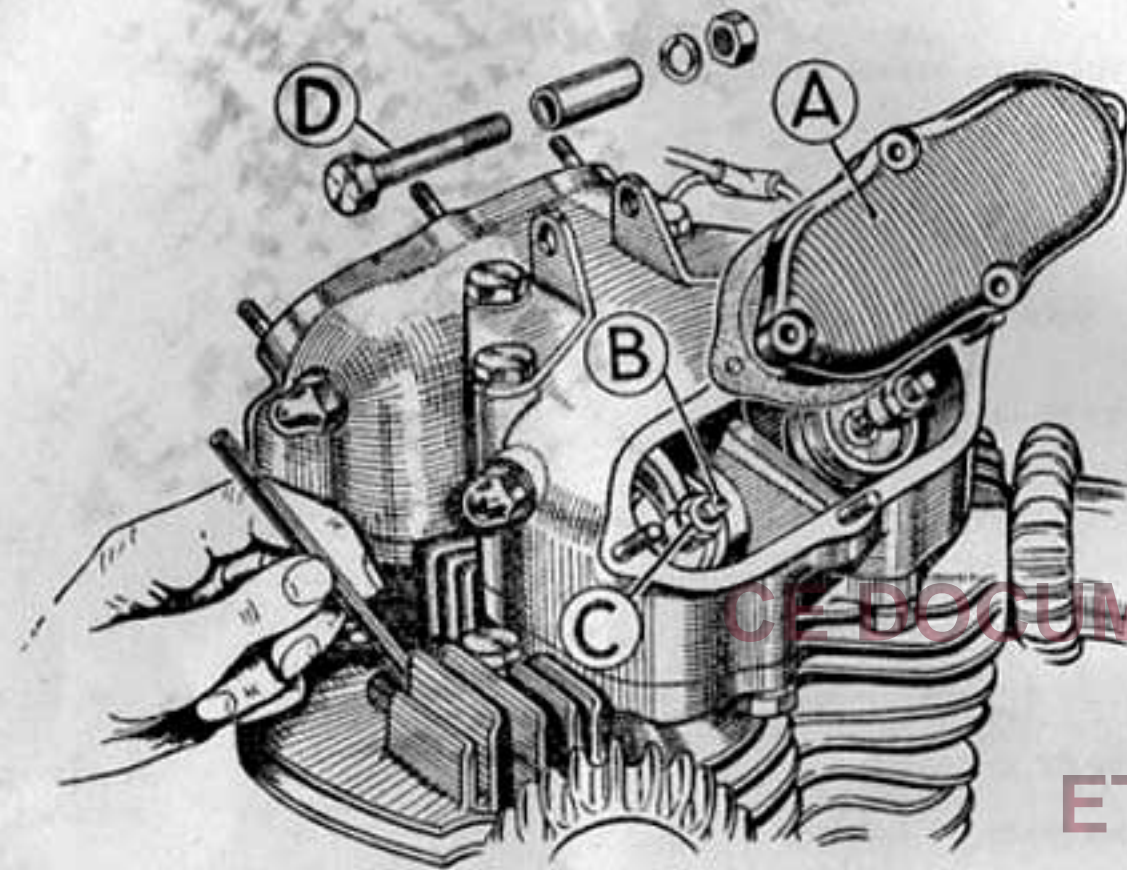

Fig. 4 Tappet Adjustment and Ignition Setting.

Rotate the engine again and adopt similar measures for the inlet valve on the opposite side of the engine. Then repeat the procedure for the two exhaust valves.

The valve clearances must only be checked or adjusted when the engine is quite cold. The clearances are critical and no attempt should be made to experiment with different settings as damage to the engine may result.

How to Adjust the Clearance.

The adjusters which are of the screwed type, are on top of the rockers immediately above the valves. The clearance is measured by means of feeler gauges inserted between the valve stem and the screw B (Fig. 4).

If adjustment is necessary, hold the tappet head B and slacken the locknut C. The tappet head B should then be moved up or down until the space between the end of the valve stem and tappet head is only just sufficient for the feeler gauge to enter. Retain the tappet head in this position and tighten the locknut securely against the rocker arm. The correct valve clearance is as follows:

	Inlet	Exhaust
A7. Standard008"	.010"
A7. Shooting Star008"	.010"
A10. Golden Flash008"	.010"
A10. Super Rocket008"	.010"

Sparkling Plug.

Adequate attention to the sparking plugs is of great importance in obtaining satisfactory engine performance, and every care should be taken to fit the correct type when replacements are necessary. There is little to be gained by experimenting with different plugs as the make and type fitted by us as official factory

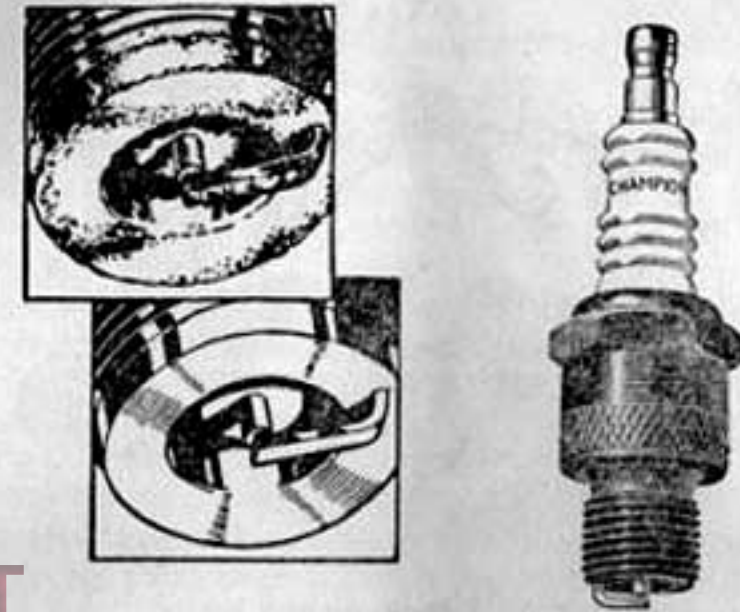

Fig. 5 The Sparking Plug.

equipment is best suited to the requirements of the engine. The makers of Champion Plugs have recently revised their schedule of type numbers and the following table gives the old and new type numbers for the recommended models.

	Old Type No.	New Type No.
A7 Standard	L10S	L7
A7 Shooting Star	NA10	N3
A10 Golden Flash	L10S	L7
A10 Super Rocket	NA10	N3

Remove the plugs every 1,000 miles (1,500 kms.) or so, for inspection. Providing that the carburation is correct the sparking plug points should remain clean almost indefinitely and should appear as shown in the lower view, Fig. 5. The bottom of the plug bodies should remain a smooth black and the central insulation should retain its natural colour. If the mixture is too rich, a sooty deposit will form on the body of the plugs as in the upper view of Fig. 5, but a weak mixture will cause the end of the plugs to go white. A heavily leaded fuel may cause a greyish deposit to form on the plugs and excess oil will show its presence by a shiny black deposit and gum.

A light deposit due to any of these causes can easily be removed by cleaning the plugs on a proper air blast unit such as is to be found at most garages, but if it is found necessary to clean the plugs frequently the cause should be investigated. If the deposit is allowed to accumulate, particularly inside the plug bodies, the plugs may spark internally with an adverse affect on performance and it may even stop the engine altogether. If eventually the cleaning process fails to restore the plugs to their original efficiency, then new ones should be fitted.

It is most important that the plug gaps are kept correct. Whenever the plugs are removed for inspection, the gaps should be tested and if necessary, re-set. The correct gaps are .018-.020 inches (.45-.50 m.m.) and they should be measured by means of feeler gauges inserted between the side wire and the central electrode. If the gaps are not correct they should be adjusted by bending the side wire, but in no circumstances must any attempt be made to bend the central electrode as this will damage the insulation and make the plugs ineffective.

The gaps are most easily adjusted with the aid of the special tool illustrated in Fig. 6, which also has feeler gauges attached to assist in measuring the plug gaps. This tool is obtainable, priced 2/-, from any Champion Plug stockist or from the Champion Sparking Plug Co. Ltd., Feltham, Middlesex.

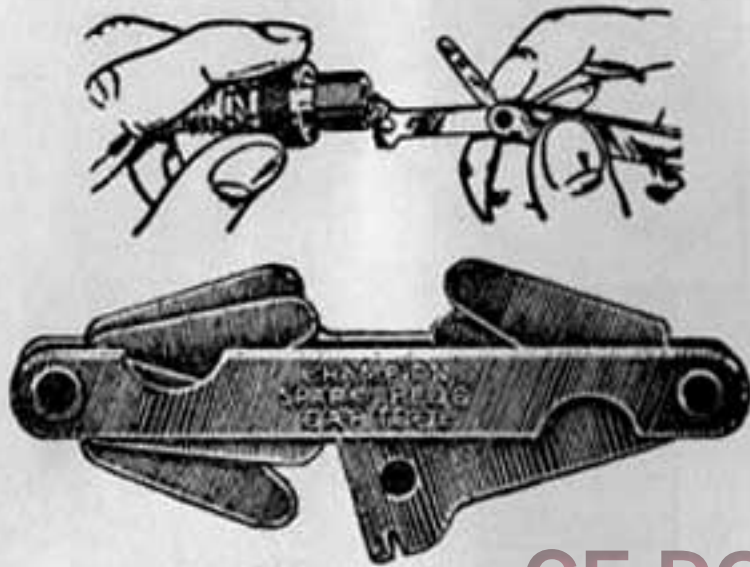

Fig. 6 Setting the plug points.

Before replacing a plug make sure that the threads are clean and that the copper washer is in good condition. If it has become worn or badly flattened a new one must be fitted to ensure a gastight seal. Screw the plug in as far as possible by hand, then use a tubular box spanner for final tightening, to avoid the possibility of damage to the insulator. In no circumstances should an adjustable spanner be used.

The insulation on top of the plugs should be wiped quite clean before replacing the caps, and then finally, the caps themselves should be wiped to remove dirt and grease.

Ignition Timing.

It is unlikely that the ignition timing will alter but if for any reason it is found necessary to check or reset the ignition timing it is advisable first to check the magneto contact breaker gap and, if necessary, re-adjust as described on page 48.

To check the timing, remove the sparking plugs and the magneto end cover. Insert a slim rod through the right-hand sparking plug hole to feel the top of the piston. Rotate the engine until the piston is at top dead centre on the compression stroke (i.e. both valves closed). Keep the rod as vertical as possible and mark the top dead centre position on it. The best way of rotating the engine is to engage top gear and turn the rear wheel.

Turn the engine backwards through about 45° then bring it forward again until the contact breaker points are just on the point of opening. This is best determined by inserting a piece of paper (such as cigarette paper) between the points. The points are just about to open when the paper is only lightly gripped and can be withdrawn with a gentle pull.

The correct position for the piston before top dead centre with the ignition fully advanced (see page 17) is:

A7.	1/8 inch
A7. Shooting Star	3/16 inch
A10. Golden Flash	1/4 inch
A10. Super Rocket	5/16 inch

as measured by the rod through the plug hole.

If the timing does require re-setting, the timing cover must be removed. This is held on by twelve screws of varying length. Note their positions for replacement purposes.

With the cover removed, release the magneto pinion from its shaft. The central nut which locks the pinion on to the shaft, also acts as an extractor (except on the Shooting Star and Super Rocket). Unscrew the nut in an anti-clockwise direction when it will eventually become tight to turn. Now remove the 'C' washer. A sharp blow on the end of the spanner will free the pinion. Note that the automatic advance mechanism is in unit construction with the pinion, and is detached with it.

On the Shooting Star and Super Rocket the magneto pinion is removed by releasing the central nut and using an extractor, Part No. 61-1903. The use of this tool is preferable to the old practice of levering the pinion off its taper with a screwdriver or other lever, as this would be liable to damage the fibre pinion. Remove the sparking plugs and rotate the engine until the timing side piston is at the top of its stroke, as described above.

Rotate the engine until the piston has descended the correct amount (see page 16) from the top of its stroke. This is best accomplished by engaging top gear and turning the rear wheel backwards by hand. A little care is necessary to ensure that the dimension given is accurately set. Now set the ignition control in the fully advanced position. On the Shooting Star and Super Rocket this is done by moving the ignition lever on the left handlebar in a clockwise direction as far as it will go. The Standard A7 and A10 Golden Flash have automatic advance, and this should be set in the following manner: If the central bridge plate is turned anti-clockwise, the governor bob-weights can be seen to move outwards against the resistance of the springs. This is the fully advanced position and the weights should be wedged as shown at B, Fig. 7, for timing purposes. Refit the magneto pinion loosely on its shaft. This is so that the shaft can be moved independently of the pinion. Rotate the contact breaker at the opposite

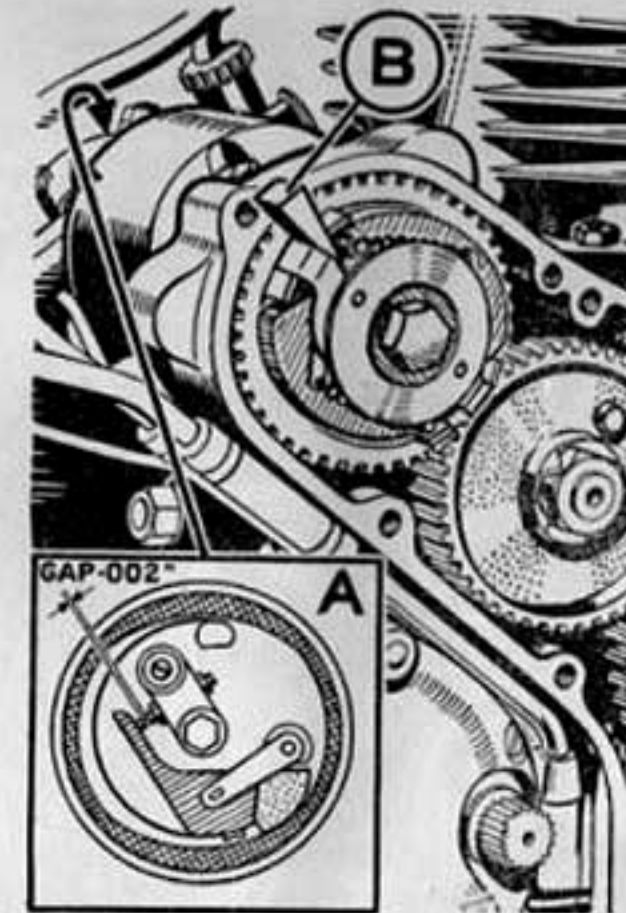

Fig. 7 Automatic Advance (A7 Standard, A10 Golden Flash)

end of the magneto, in its normal direction of rotation until the contact breaker points are just open (not more than .002 inches), see A, Fig. 7. Press the magneto pinion home on to its taper, and carefully check the ignition setting. If it is correct, tighten the central nut. Do not forget to move the wedge from the governor bob-weights on the standard A7 and A10 Golden Flash. Finally, replace the timing cover (renew the paper gasket to ensure an oil tight joint), together with the tappet inspection covers, and the sparking plugs.

It cannot be too strongly emphasized that the ignition timing must be correctly set for satisfactory engine performance, and also that any temptation to improve upon the maker's setting should be avoided, as this setting has been found best after careful trial and experiment. The fact that A7 Standard and A10 Golden Flash engines are fitted with automatic ignition advance makes it all the more necessary that the above timing instructions should be faithfully carried out.

Valve Timing.

Under normal running conditions the valve timing cannot become disturbed, and it is inadvisable to dismantle the timing gear train unless absolutely essential. Should it be necessary, however, to check the timing, the following procedure should be observed, components being removed in the following order:

Remove the timing cover by unscrewing the fixing screws, noting their positions for replacement purposes. The dynamo chain is of the endless type (i.e. there is no connecting link), so that the chain and the large sprocket must be taken off together. The sprocket fits on to a tapered shaft without a key, and after removing the nut and locking washer, the use of a suitable extractor is advisable to avoid possible damage to the cover. Alternatively, apply a spanner to the dynamo sprocket nut and give it a sharp blow in a clockwise direction, with the chain in

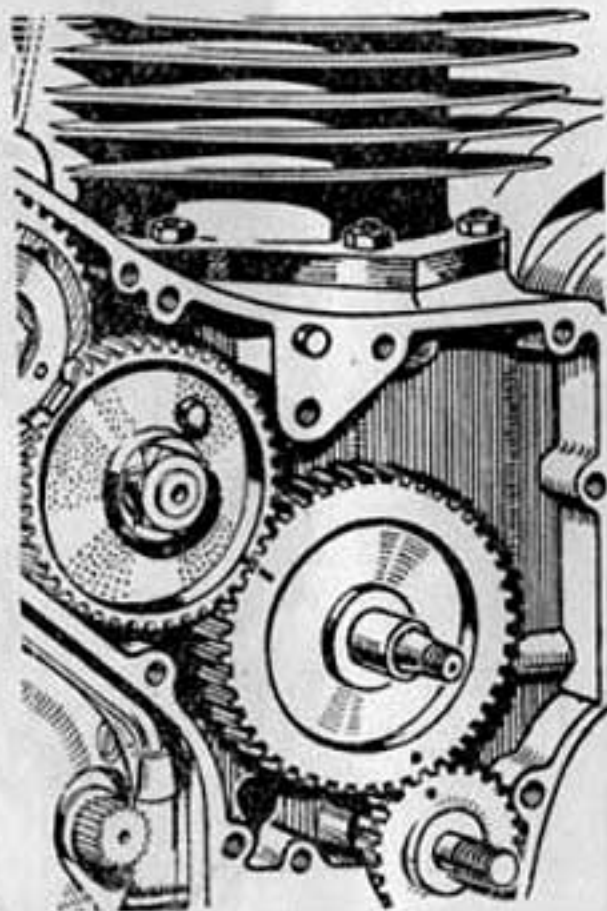

Fig. 8 Valve Timing Marks.

position. This should free the large sprocket. Once this sprocket is withdrawn from its spindle, the chain may be lifted off the small sprocket, leaving the latter in position on the dynamo spindle.

The dynamo strap should be slackened to enable the dynamo to be rotated by hand to a suitable position, so that its sprocket can pass through the aperture in the inner timing cover, when the latter is removed. This is held in position by four screws, and it should now be detached. The breather sleeve will probably remain in the cover, leaving the cork washer adhering to the camshaft gear. Then examine the camshaft gears, verifying that their markings correspond with those shown in Fig. 8. It may be necessary to rotate the engine several times before the marks appear in their correct positions.

During re-assembly, make sure that the breather cork washer is intact (replacing if necessary) and that the driving peg in the camshaft gear engages with the hole in the breather sleeve. Remember to bend the locking washer into position on the large dynamo chain sprocket after tightening the nut. Before tightening the dynamo strap, press the dynamo firmly against the back of the timing case to ensure an oil tight joint by trapping the cork seal. Finally, fit new paper washers between the cover joint faces.

Cylinder Head.

After the machine has covered its first 250 miles when new or after decarbonising, check the tightness of the cylinder head bolts. This is because the gasket tends to settle down after the initial clamping. To ensure even distribution of pressure with consequent freedom from distortion, tighten the bolts in rotation as shown in Fig. 9. In the case of aluminium alloy heads do this when the engine is cold.

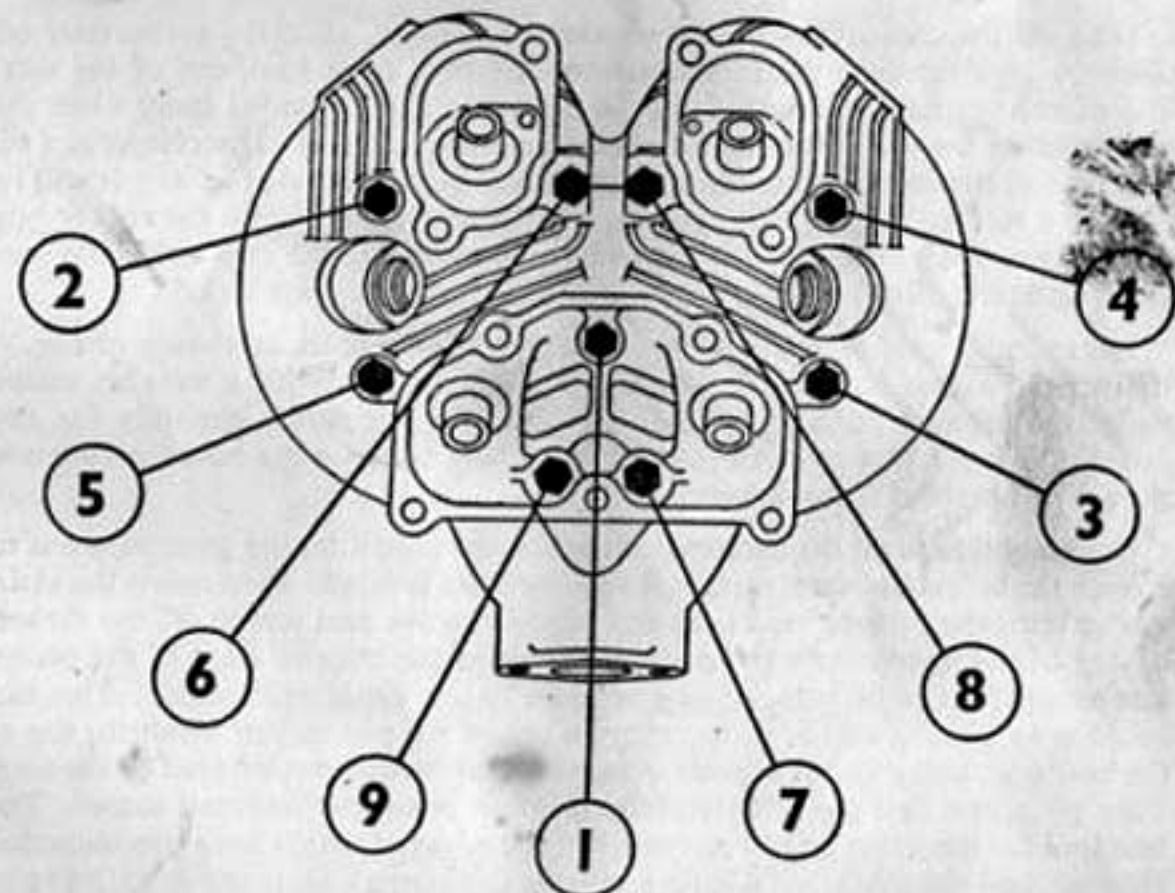

Fig. 9 Cylinder Head Bolts

CE DOCUMENT EST GRATUIT
 RIEN NE PEUT
 EN AUCUN CAS
 ÊTRE VENDU

end of the magneto, in its normal direction of rotation until the contact breaker points are just open (not more than .002 inches), see A, Fig. 7. Press the magneto pinion home on to its taper, and carefully check the ignition setting. If it is correct, tighten the central nut. Do not forget to move the wedge from the governor bob-weights on the standard A7 and A10 Golden Flash. Finally, replace the timing cover (renew the paper gasket to ensure an oil tight joint), together with the tappet inspection covers, and the sparking plugs.

It cannot be too strongly emphasized that the ignition timing must be correctly set for satisfactory engine performance, and also that any temptation to improve upon the maker's setting should be avoided, as this setting has been found best after careful trial and experiment. The fact that A7 Standard and A10 Golden Flash engines are fitted with automatic ignition advance makes it all the more necessary that the above timing instructions should be faithfully carried out.

Valve Timing.

Under normal running conditions the valve timing cannot become disturbed, and it is inadvisable to dismantle the timing gear train unless absolutely essential. Should it be necessary, however, to check the timing, the following procedure should be observed, components being removed in the following order:

Remove the timing cover by unscrewing the fixing screws, noting their positions for replacement purposes. The dynamo chain is of the endless type (i.e. there is no connecting link), so that the chain and the large sprocket must be taken off together. The sprocket fits on to a tapered shaft without a key, and after removing the nut and locking washer, the use of a suitable extractor is advisable to avoid possible damage to the cover. Alternatively, apply a spanner to the dynamo sprocket nut and give it a sharp blow in a clockwise direction, with the chain in

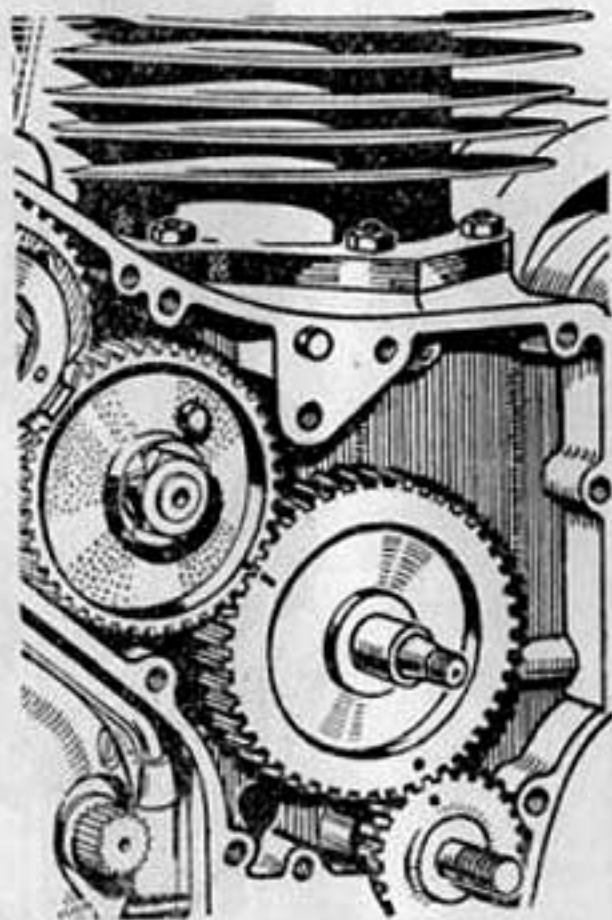

Fig. 8 Valve Timing Marks.

position. This should free the large sprocket. Once this sprocket is withdrawn from its spindle, the chain may be lifted off the small sprocket, leaving the latter in position on the dynamo spindle.

The dynamo strap should be slackened to enable the dynamo to be rotated by hand to a suitable position, so that its sprocket can pass through the aperture in the inner timing cover, when the latter is removed. This is held in position by four screws, and it should now be detached. The breather sleeve will probably remain in the cover, leaving the cork washer adhering to the camshaft gear. Then examine the camshaft gears, verifying that their markings correspond with those shown in Fig. 8. It may be necessary to rotate the engine several times before the marks appear in their correct positions.

During re-assembly, make sure that the breather cork washer is intact (replacing if necessary) and that the driving peg in the camshaft gear engages with the hole in the breather sleeve. Remember to bend the locking washer into position on the large dynamo chain sprocket after tightening the nut. Before tightening the dynamo strap, press the dynamo firmly against the back of the timing case to ensure an oil tight joint by trapping the cork seal. Finally, fit new paper washers between the cover joint faces.

Cylinder Head.

After the machine has covered its first 250 miles when new or after decarbonising, check the tightness of the cylinder head bolts. This is because the gasket tends to settle down after the initial clamping. To ensure even distribution of pressure with consequent freedom from distortion, tighten the bolts in rotation as shown in Fig. 9. In the case of aluminium alloy heads do this when the engine is cold.

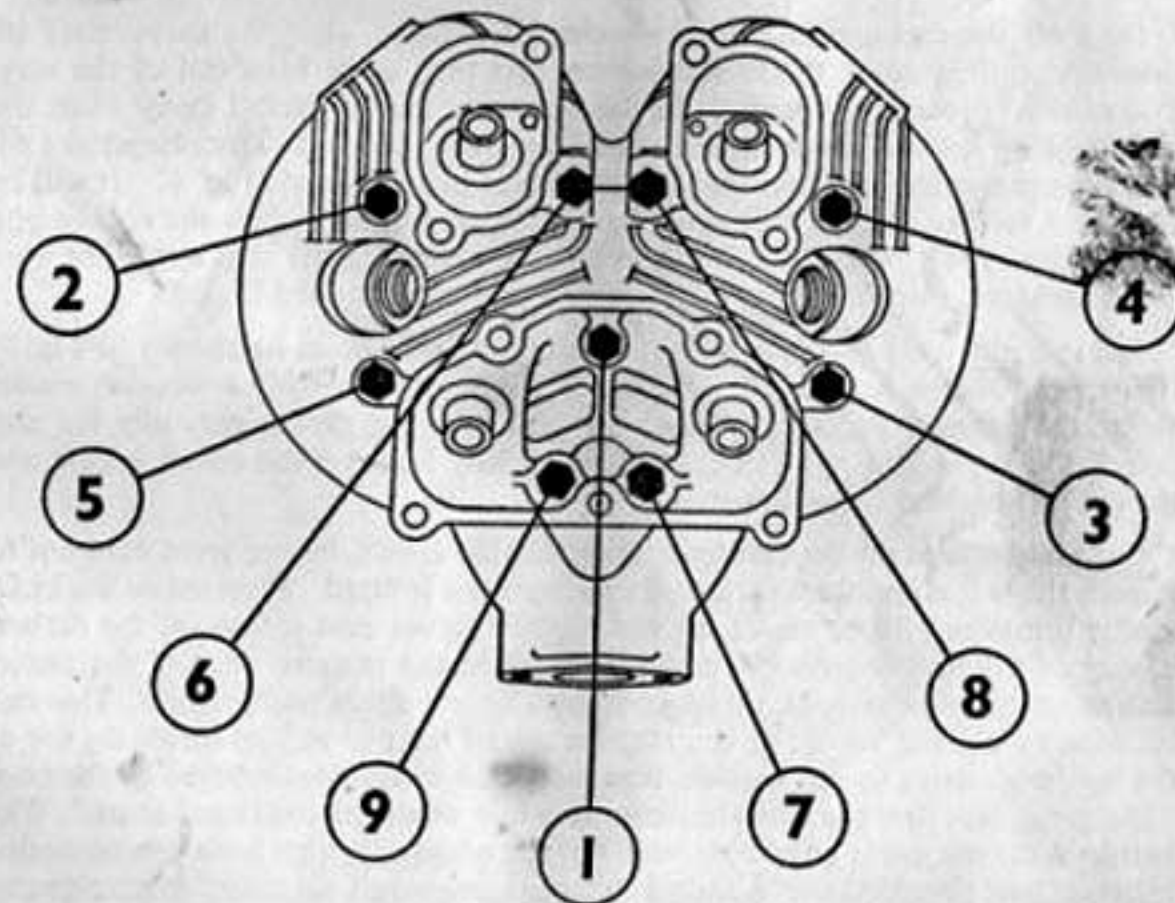

Fig. 9 Cylinder Head Bolts

Automatic Advance Unit. (Fig. 7. A7. Standard and A10. Golden Flash only.)

This is contained within the timing case and is in unit construction with the magneto pinion. Attention to the unit can be given after removal of the timing cover, which is retained by twelve screws of varying lengths. Note these for replacement purposes.

Examine the automatic advance unit making sure that the governor bob-weights move freely and that if the unit is turned by hand to the advance position (weights fully extended outwards) and released, the springs withdraw the weights to the inner position (retarded).

If necessary lubricate thoroughly with engine oil.

Decarbonisation.

Decarbonisation should only be carried out when there are definite symptoms that excessive carbon build-up inside the engine is interfering with performance. The usual symptoms are an increased tendency to pink (a metallic knocking when under load) and a general falling off in performance with a tendency for the engine to run hotter than usual.

It is customary to attend to the valves during decarbonisation as this provides a reasonable interval between valve overhaul and avoids the necessity for dismantling the engine especially for this purpose at a later date.

It is necessary to remove the petrol tank in order to carry out decarbonisation. Turn off the petrol and detach the petrol pipes. Remove the petrol tank strap which is located under the front of the tank, and is held in position by two nuts. The central tank locking bolt can then be removed after the rubber plug in top of the tank is pulled off. Next detach the high tension leads and the sparking plugs. Disconnect the engine steady stay by unscrewing the bolt D, Fig. 4.

Take off the carburetter. If an air cleaner is fitted, slide the carburetter off sideways to disconnect the rubber sleeve, and then tie it back out of the way. The exhaust pipes are a push fit in the head and can be pulled away when the nuts holding the exhaust system to the frame are released. Disconnect the oil feed pipe to the rockers, and remove the rocker box covers A, Fig. 4. It will be necessary to take out the front stud inside the rear cover before the rocker box can be removed. Finally undo the five bolts, including the one inside the rear cover aperture, also four nuts under the rocker box and then lift off.

The cylinder head is taken off by removing the nine bolts as shown in Fig. 9. If the head shows a tendency to stick, a few light taps with a wooden mallet under the exhaust ports will loosen it. Examine the gasket carefully for any defects. If it has brown patches on it, especially between the bores, a new one should be obtained for re-assembly.

Carefully scrape all the carbon from inside the heads, taking great care not to scratch the soft aluminium surface if an alloy head is fitted. Then rotate the kick-starter until the pistons are at the top of their stroke and scrape off the carbon on top of the pistons. As the carbon deposit at the extreme edge of the piston acts as an effective oil seal, it is a good idea to leave this undisturbed. This can be done by placing an old piston ring on top of the piston, just inside the top of the bore and, using this as a guide, remove all the carbon not covered by the ring. Take great care that the soft aluminium surface of the piston is not scored. The best tool for the job is an old screwdriver, the edges of which have been rounded by wear, and provided that a little patience is employed, all traces of carbon can be removed to leave the surface smooth and unmarked.

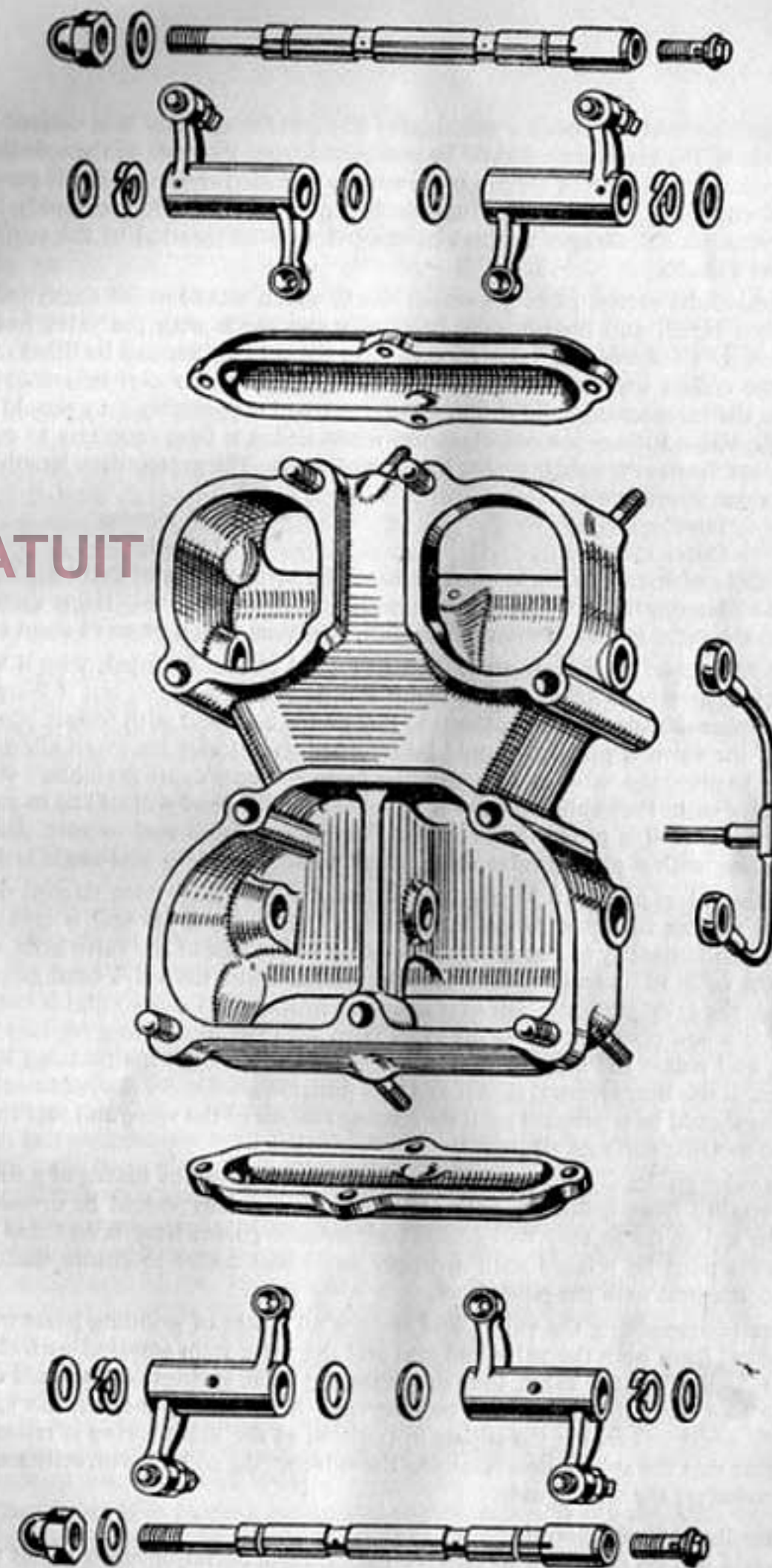

Fig. 10 Rocker Assembly.

It is unlikely that the rockers will require any attention, but if it is desired to remove them, the acorn nuts should be unscrewed from the ends of the spindles. The spindles should then be tapped out from the threaded end using a soft punch to avoid damaging the threads. Take careful note of the rocker assembly for replacement, as the various washers must obviously be inserted in the correct order (see Fig. 10.)

To remove the valves, place a wooden block, which will fit inside the cylinder head, on a bench and then lay the head over the block with the valve heads resting on it. Compress the valve springs until the split collets can be lifted out. When the collets are out, the valve springs and top collar can be removed. Examine the valve springs and if they have shortened appreciably they should be replaced. Valve springs are not expensive items and it is false economy to continue to use them when their useful life is exhausted. The correct free length of these springs when new is:

Inner spring	1 $\frac{11}{16}$ inches
Outer spring	1 $\frac{1}{8}$ inches

The inside of the valve ports must be carefully scraped free of carbon. Take care not to damage the valve seat faces with the decarbonising tool. If any carbon falls into the valve guides, it must be carefully removed with a piece of clean rag.

If the valves and their seats are only discoloured or lightly pitted, then it will be sufficient merely to grind them in with a little grinding paste, but if there is considerable evidence of pitting, then the faces must be re-cut with proper equipment. If the valve is pitted it should be returned to a dealer for re-grinding, as attempts to grind the valve in with grinding paste will only cause premature wear of the valve seat. Probably the valve seat in the cylinder head will still be in good condition, but if it is pitted the head must be removed and sent to your dealer for re-facing with a proper valve seat cutting tool. The valve seat angle is 45°.

With the valves and seats in good condition or if they have been refaced then they will require lightly grinding in to ensure that a good gas seal is created. Smear a small quantity of fine grinding paste on to the face of the valve head and return the valve to its seat. A light spring inserted under the valve head greatly facilitates the grinding operation as it assists in raising the valve so that it can be rotated to a new position. Hold the valve stem with the special tool provided in the kit, and rotate the valve backwards and forwards whilst maintaining light pressure. Raise the valve and turn it to a new position after every few movements. Grinding should be continued until the mating surface of the valve and seat show uniform metallic surfaces all round.

If the valve guides are worn the old ones can be driven out by means of a single punch applied from inside the cylinder head. New guides should be driven in from the top as far as they will go. Whenever new guides have been fitted the valve seats must be refaced with a proper valve seat cutter to ensure that the seat is concentric with the guide bore.

Before re-assembling the valves and springs all traces of grinding paste must be removed from both the valve and seat and the valve stem smeared with clean engine oil. Replace the valve, then compress the valve springs with the aid of a suitable tool until the collets can be inserted. A blob of grease on the valve stem will assist in keeping the collets in position as the valve spring is released. Make sure that the split collets retaining the valve spring collar is correctly seated in the recess on the valve guide.

Removing the Cylinder Barrel.

It should not be necessary to remove the cylinder barrel unless it is felt that the piston rings require attention. This may be shown by such symptoms as

excessive blue smoke in the exhaust and by lack of compression, although if the valves are not in good condition this is more likely to be the cause of the latter symptoms.

Rotate the engine until the pistons are at the bottom of their stroke, remove the cylinder base nuts (9 in all) and carefully lift the block upwards until the pistons are clear of the bores. It is as well to have an assistant to steady the pistons as they emerge from the block, to avoid possible damage. As soon as the barrel has been withdrawn, cover the crankcase with a clean piece of cloth to keep the dirt out. Scrape the paper washer off the cylinder base flange and/or the crankcase face.

Examine the cylinders carefully for wear and if a deep ridge has formed at the top of the bores then a rebore may be necessary and you should consult your dealer for confirmation. Pistons $\frac{1}{4}$ mm. and 1 mm. oversize are available for re-bore purposes, but owners in Great Britain can take advantage of the Exchange Replacement System to obtain a rebored barrel with matched piston, through their local B.S.A. spares stockist. The barrel will also require a rebore if there are any deep scores as these will cause loss of compression and excessive oil consumption. Any shiny marks on the bores are an indication of seizure and the cause of this should be determined and rectified.

The outside face of the piston rings should possess a smooth metallic surface and any signs of discolouration or shiny portions mean that the rings must be replaced. The rings must also possess a certain amount of springiness so that the ends lie at least $\frac{1}{8}$ inch apart when released from the barrel.

The rings should be free in their grooves but with a minimum side clearance. If the rings are stuck in the grooves remove them and clean out all the carbon from the groove and the inside face of the ring. Care is necessary when removing the rings as they are brittle and only permit a minimum amount of movement. A suitable tool for removing the carbon from the ring grooves is a piece of old piston ring ground as a chisel.

To check the piston ring gaps place each ring in the least worn part of the cylinder bore and make sure that it is square in the bore by locating it with the top of the piston. Measure the gap between the end of the ring with a feeler gauge. The correct gap when new is .009-.013 inches and although an increase of a few thousandths of an inch is not important, any large increase to say, 25 thou. means that the ring should be replaced. If a new ring is being measured the gap may be less than the amount specified and in this case the ends of the ring must be opened out with the careful use of a very fine file. Take care that no ridge is left on the edges of the ring which could score the barrel.

It is not necessary to remove the pistons unless they require replacement or further dismantling of the engine is being carried out. To remove a piston, first prise out one of the wire gudgeon pin circlips by inserting a suitable pointed instrument in one of the notches provided. Before the gudgeon pin can be withdrawn, the piston must be warmed by wrapping it in a cloth that has been immersed in boiling water and wrung out. Alternatively, an electric iron can be applied to the crown of the piston until it is thoroughly warm. When the piston is warm, tap out the gudgeon pin with a light hammer and a punch of suitable diameter. The pistons must be carefully supported to avoid any side strain on the connecting rods.

Re-assembly is carried out in the reverse order to dismantling. Scrupulous cleanliness must be observed and the components should be smeared with fresh oil before replacing.

All A. Model engines except the Super Rocket are fitted with split skirt pistons and the diagonal cut must be at the front. Make sure also that the pistons are on the same connecting rods from which they were removed.

Warm the pistons before inserting the gudgeon pins and make sure that the new circlips are correctly located in their grooves. Slide each piston ring carefully over the pistons, until it reaches its groove. Fit a new paper washer to the crankcase face, lightly smearing with jointing compound before doing so. Before replacing the cylinder barrel, prepare two strips of wood $\frac{1}{4}$ inch square by about 8 inches long, so that they can be laid across the crankcase mouth under the pistons (one in front and one behind). These will enable the pistons to be held square while the barrel is lowered. It will simplify the fitting of the barrel if the piston rings are compressed into the grooves by means of piston ring compressors, so that as soon as the pistons enter the bores, the clips will automatically be pushed off, when they and the two wooden strips can be moved away before the barrel is finally lowered into position.

Replace the cylinder head gasket and cylinder head, tightening down the bolts as shown in Fig. 9, to prevent risk of distortion. The push rods can now be replaced by inserting them down the push rod apertures in the head and fitting them into their respective tappet cups.

Note: The exhaust push rods are longer than the inlet rods. Make sure that the push rods are correctly inserted into the rocker ends, and tighten the rocker box down. This must be done carefully to avoid straining the rocker box due to the action of the valve springs. There are four nuts below the rocker box, and five bolts above the rocker box, one of which is accessible through the rear tappet cover. Remember to replace the engine steady stays Fig. 4, when tightening down the remaining four bolts.

Check the tappet clearances as described on page 14, and replace the covers A Fig. 4. Connect the oil feed pipe to the rockers. Clean and adjust the sparking plugs as described on page 14, and then connect the H.T. leads, making sure that each is coupled to its correct plug. Replace the carburetter, but if an air cleaner is fitted the rubber connection should be attached to the carburetter before it is finally bolted on to the cylinder head. Replace the exhaust system, check all nuts and bolts and finally replace the petrol tank and petrol pipes.

CARBURATION

The carburetter is of simple and robust construction and the only attention that may be required is adjustment of the pilot jet and throttle stop.

An exploded view of the carburetter is shown in Fig. 11. Opening the twist grip throttle control raises the throttle slide thus controlling the supply of air to the engine. The tapered needle controlling the supply of fuel is attached to the throttle slide so that a balanced mixture is always provided. The needle has five notches at its upper end and it is secured in the throttle slide by a spring clip which locates in one of these notches. The throttle valve size and the needle position are carefully set before despatch from the factory and no alteration to these settings is necessary or desirable. An air valve controlled by the lever on the handlebar is used to restrict the air supply when starting the engine from cold.

Mixture control at tickover and low speeds is controlled by the pilot jet which has an adjustable air supply. An adjustable throttle stop is also provided to regulate the slow running speed.

To achieve good petrol economy accurate adjustment of the pilot jet and throttle stop is important. These are adjusted before the machine leaves the Works, but

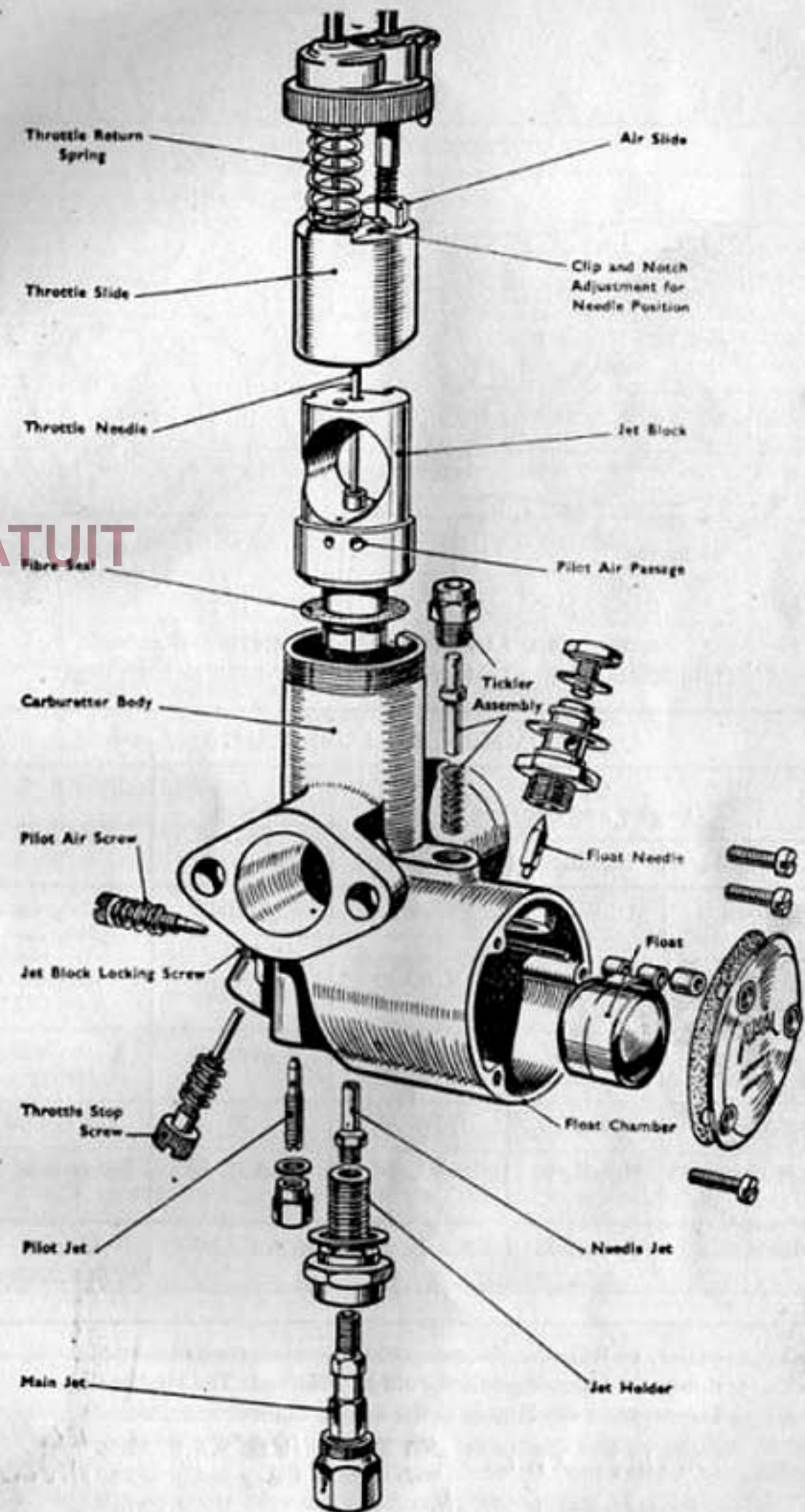
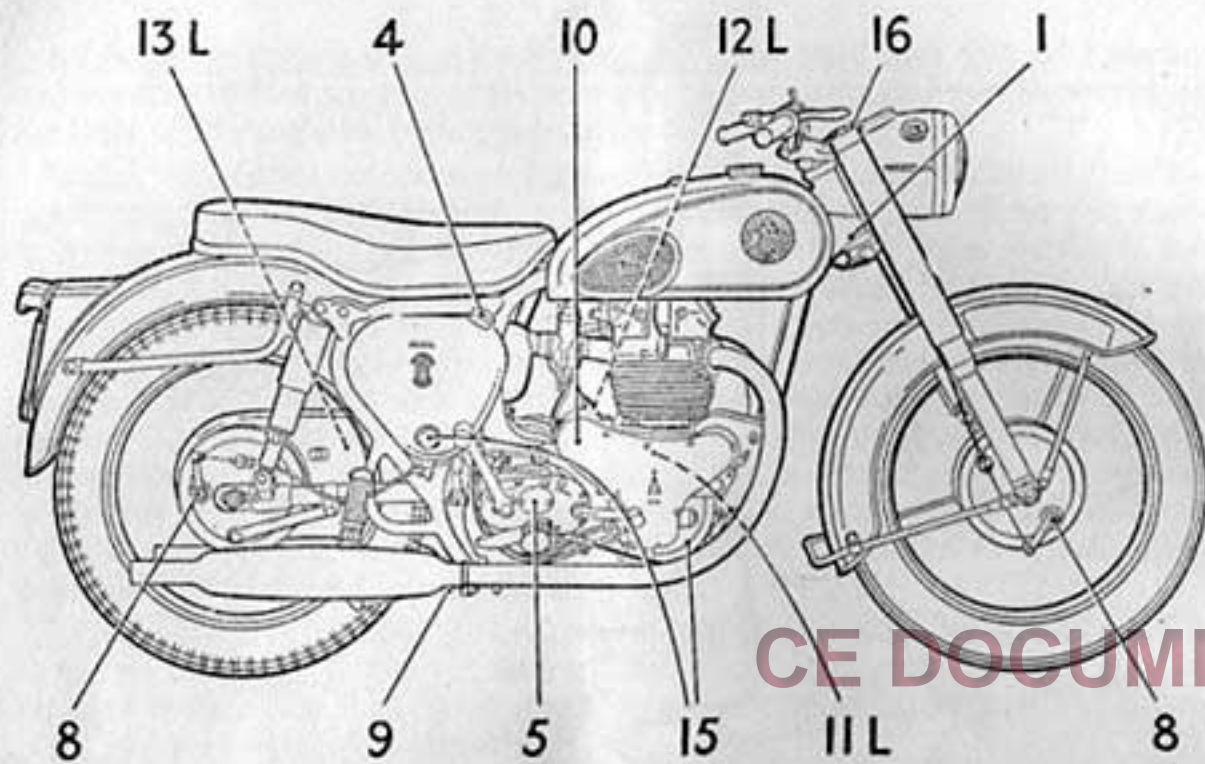

Fig. 11. The Carburetter.



KEY LUBRICATION POINTS

(L indicates left-hand side, remainder right-hand or both sides).

RECOMMENDED LUBRICANTS				
OILS (Engine and Gearbox)			Front Forks	GREASE
Brand	Summer	Winter		
Mobiloil	BB	A	Arctic	Mobilgrease No. 2.
Shell	X100-40	X100-30	X100-20	Retinax A or CD
Castrol	XXL	XL	Castrolite	Castrolase Heavy
Esso Extra	40/50	20W/30	20	Essogrease
B.P. Energol	S.A.E. 40	S.A.E. 30	S.A.E. 20	Energrease C.3
Havoline	S.A.E. 40	S.A.E. 30	S.A.E. 20W	Marfak Multipurpose 2

FOR OVERSEAS. Recommendations as above if obtainable. If not, the following rule should be observed: The Higher the Temperature the Higher is the S.A.E. number required.

Engine and Gearbox: ~~Summer~~ S.A.E. 40-50 *EG*
~~Winter~~ S.A.E. 40-20 *Hiver*

Front Forks: *fourche* S.A.E. 20.

WEEKLY LUBRICATION					
Ref.	GREASE	Page	Ref.	OIL	Page
			4	Oil Tank	—
			5	Gearbox	—
			—	Control Rod Joints and	10
			—	Exposed Cables	10

LUBRICATION EVERY 1000 MILES					
Ref.	GREASE	Page	Ref.	OIL	Page
1	Steering Head	11	13	Rear Chain	11
—	Clutch Control Arm	11			
8	Brake Cam Spindles	11			
9	Central Stand	11			

LUBRICATION EVERY 2000 MILES					
Ref.	GREASE	Page	Ref.	OIL	Page
			4	Oil Tank	11
			5	Gearbox	11
			10	Auto and Manual Advance	17
			11	Primary Chain Oilbath	30
			12	Magneto	11

SPECIAL NOTES

Examine Engine Pressure Valve at 1,000 miles. (See A. Fig. 3)

15. Clean Oil Tank and Crankcase Filters at 2,000 miles.

16. Check Front Fork Oil Level at 10,000 miles.

the best setting may vary slightly to suit riders' requirements or particular localities. The adjustment should be made with the engine warm.

Screwing in the pilot air screw restricts the air supply thus giving a richer mixture, and unscrewing it weakens the mixture. The best way to adjust is to screw in the pilot air screw until the mixture is obviously too rich and the engine starts to run irregularly then unscrew the adjuster until the engine runs evenly. If it is unscrewed too far the engine may cut-out or may spit back through the carburetter when the throttle is opened. When the proper adjustment has been determined, the engine may be running too fast and in this case the throttle stop should be unscrewed until a steady and even tickover is achieved. If considerable alteration to the throttle stop has been made, the pilot air screw should be re-adjusted. Do not attempt to obtain an excessively slow tickover as it will probably become unreliable under different atmospheric conditions. In the case of blockage, the jets are easily exposed for cleaning by simply removing the covering caps. The main jet can then be unscrewed with a suitable spanner and the pilot jet with a screwdriver. No advantage will be gained by altering the jet sizes from those recommended.

Air Cleaner.

The air cleaner should be removed occasionally for cleaning. Every 5,000 miles should be sufficient in the British Isles but more frequent attention is necessary in dustier regions.

A7. Standard; A10. Golden Flash.

Uncouple the rubber connection at the carburetter end, then undo the two bolts in slotted holes which secure the filter body and lift it out sideways.

The filter is secured in the body by a wire circlip which can be prised out with a screwdriver.

A7. Shooting Star. (When fitted).

Unscrew the filter from the carburetter body. The filter is held in the cleaner cover by a single screw. Remove this screw to detach the filter.

All Models.

Wash the filter thoroughly in petrol to remove all embedded dirt, then allow it to dry thoroughly. Finally, immerse the filter in a thin oil (S.A.E.20), allow the surplus to drain off, then re-assemble.

TRANSMISSION

Primary Chain Adjustment.

Adjustment of the primary chain is effected by pivoting the gearbox about its lower support bolt. The chain is correctly adjusted when it has $\frac{1}{2}$ inch total up and down movement in the centre of the chain span and at its tightest point. This can be gauged by removing the primary chain case inspection cover and moving the chain up and down. Make sure that the chain is at its tightest spot. If the chain requires adjustment slacken the two nuts A and B (Fig. 12). Slacken the locknut C and screw the adjuster D backwards or forwards as necessary until the adjustment is correct. Tighten the locknut C and the two clamping nuts A and B, then re-check the adjustment. Whenever the primary chain adjustment has been altered, the rear chain must be re-adjusted. (see Page 37).

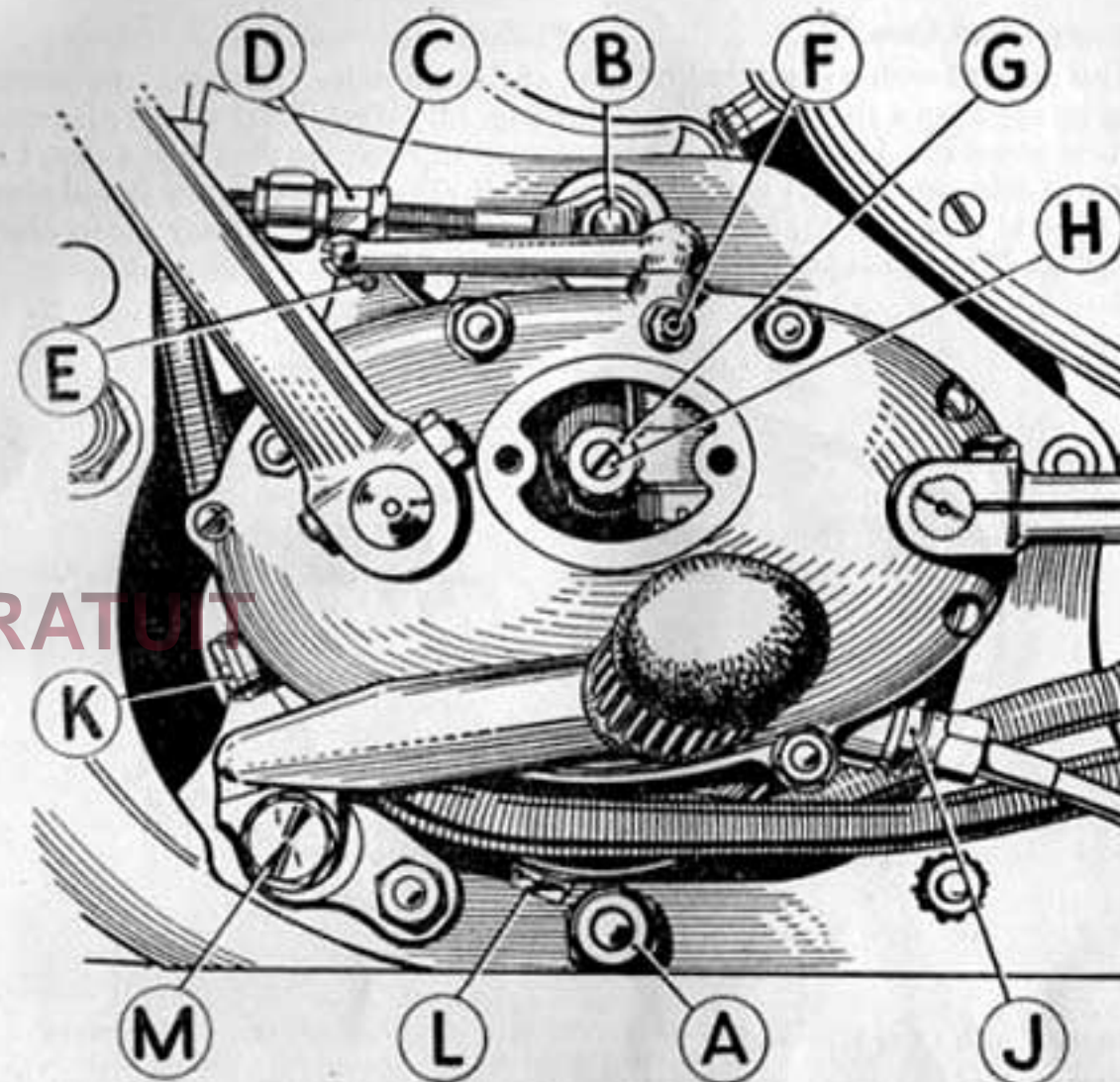

Fig. 12 Clutch and Front Chain Adjustment.

Care of the Rear Chain.

To maintain the rear chain in good condition it must be lubricated regularly. Every 1,000 miles or so remove the chain and wash it thoroughly in petrol to remove all dirt and grease. Allow the chain to dry completely, then immerse it in a tray containing warm graphited grease. Allow the mixture to cool, then remove the chain and wipe off all surplus grease. When replacing the chain make sure that the spring clip of the connecting link has its closed end pointing in the direction of travel of the chain (i.e. forwards on the top run). On machines fitted with a fully enclosed rear chain guard this attention should not be necessary except at prolonged intervals.

Rear chain adjustment involves moving the rear wheel and is described on Page 36.

Clutch Adjustment.

The main clutch adjustment is inside the inspection cover on the gearbox. Remove the two screws and lift the cover away. Slacken the locking nut G (Fig. 12) to free the adjusting screw H. The adjustment should be made so that when the clutch is fully withdrawn the lever on top of the cover is at right angles to the clutch push rod. This ensures that the minimum side thrust is imposed on the push rod. When this adjustment has been completed the cable should be adjusted by means of the adjuster at E until it has approximately $\frac{1}{4}$ inch free play at the handlebar end.

Primary Chain Case.

This is fitted with a combined oil level and drain plug. To drain remove the plug by applying a spanner to hexagon A Fig. 13. To refill replace the plug and remove screw B. Fill with seasonal engine oil through the plug hole C until it starts to drip out through the hole for screw B. Then replace screw B and plug C. Mineral base seasonal engine oil should be used in the primary chain case. (See Page 26). The chain case oil capacity is eight fluid ozs. (225 c.c.).

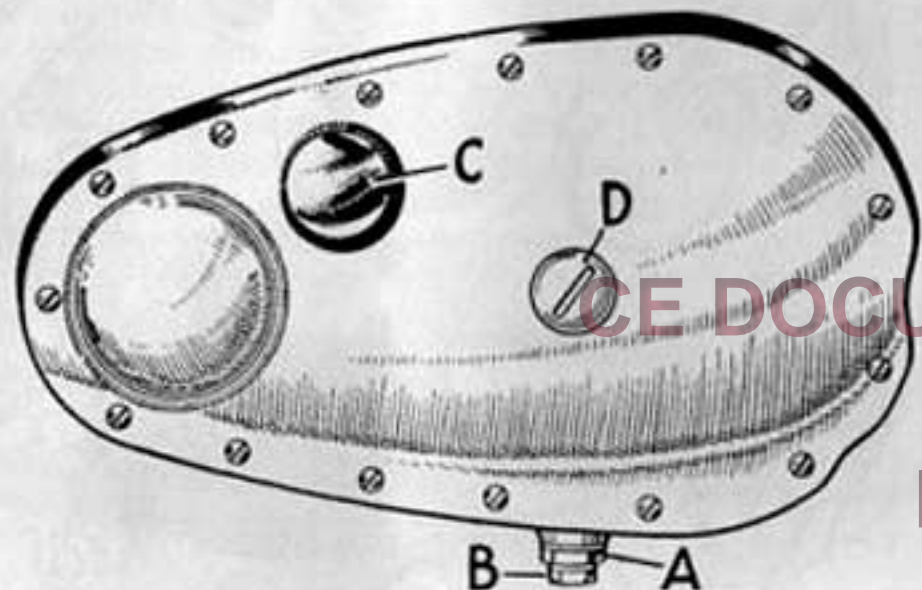

Fig. 13 Primary Chain Case.

Primary Chain Case Removal.

Removal of the retaining screws and the left hand footrest will permit the primary chain case outer cover to be withdrawn. The engine sprocket and clutch must be removed to allow further dismantling. The rear of the chain case is secured to the crankcase by three bolts behind the engine sprocket and these can be undone after breaking the locking wire through the head of the bolts. A single bolt at its lower rear end secures the rear of the chain case to the frame.

Clutch Spring Adjustment.

After considerable use it may be necessary to increase the spring pressure a little. To do this remove plug D Fig. 13 and screw in each of the six adjuster nuts seen in Fig. 14, bringing them into position successively by operating the kick starter, and giving each the same amount of adjustment (say two turns). Withdraw the clutch to ensure that it frees properly and that the end plate does not tilt. If the plate does tilt the clutch will not free properly and the springs should therefore be re-adjusted until the plate remains square when the clutch is withdrawn.

Engine Sprocket Removal.

Insert a screwdriver between the coils of the engine shaft shock absorber spring and prise up the bent-over tab of the lockwasher. The mainshaft nut can then be undone. If any difficulty is experienced due to the engine rotating, engage top gear and apply the back brake. Remove the spring and sliding sleeve. Detach the primary chain by undoing the spring link. The engine sprocket and the central splined sleeve can then be withdrawn from the engine mainshaft.

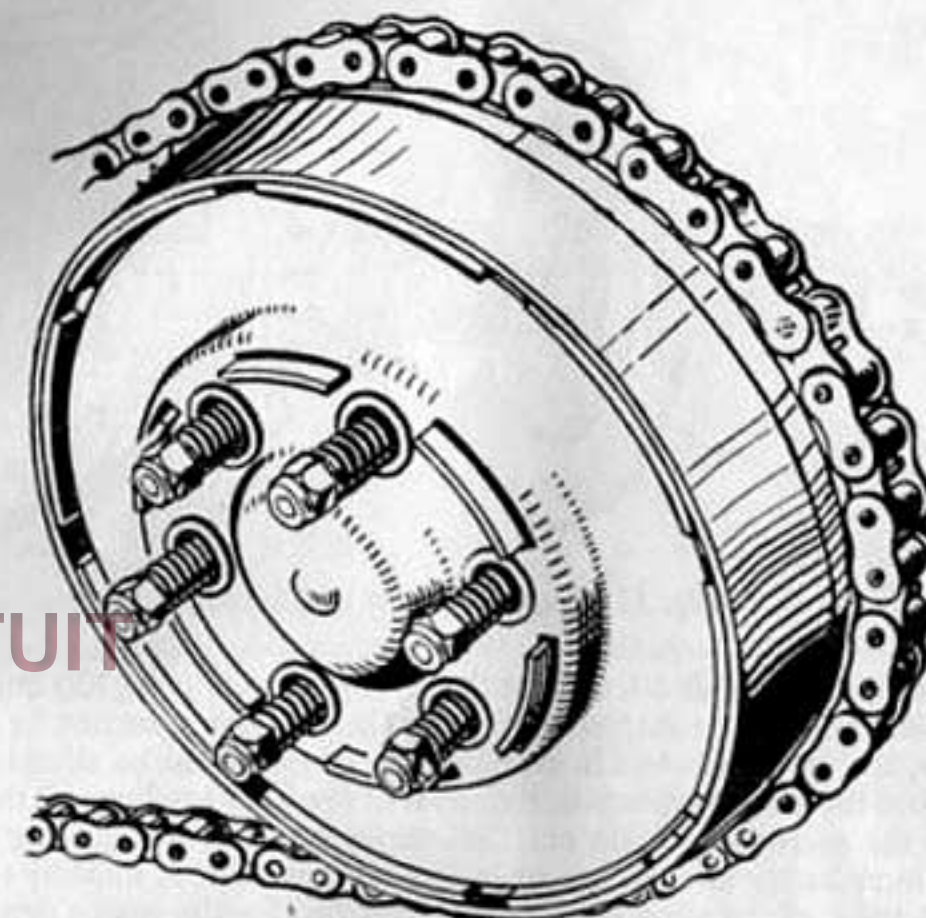

Fig. 14 Clutch Spring Arrangement.

Clutch Dismantling.

Removal of the six locknuts and spring retaining nuts will allow the clutch end plate to be withdrawn. Bend back the locking washer and undo the large central nut. To prevent the shaft turning, engage top gear and apply the back brake. With this nut removed the complete clutch, with the exception of the central splined sleeve, can be withdrawn. Wash the plates in petrol to remove any surplus oil, and examine them carefully. If obvious signs of glazing are present the friction plates must be replaced. Replacements must also be made if any of the plain plates are scored.

The chain wheel and central cage must be examined for burrs which might prevent the plates sliding freely. If these are not serious they can be removed with a smooth file. In the case of a machine which has seen considerable service the sprocket teeth should be examined for wear, as worn teeth soon cause the chain to deteriorate very rapidly. The ball race must not possess more than .0015 inch diametral play, as wear in this bearing may provoke clutch slip.

The central splined sleeve engages on a taper on the gearbox mainshaft, and can only be removed with the aid of a special screwed extractor, Part No. 61-3362, which can be obtained from a B.S.A. spares stockist. A key also serves to locate the sleeve, and this must be replaced correctly during re-assembly. The order for re-assembly is as shown in Fig. 15. Take particular care that the large central nut is done up quite tight after the locking washer has been correctly located on the splined sleeve. Turn the washer down over the flat on the outside of the nut.

Gearbox.

The gearbox is of straightforward design employing constant mesh gears. Apart from occasionally topping up or changing the oil, very little maintenance should normally be required.

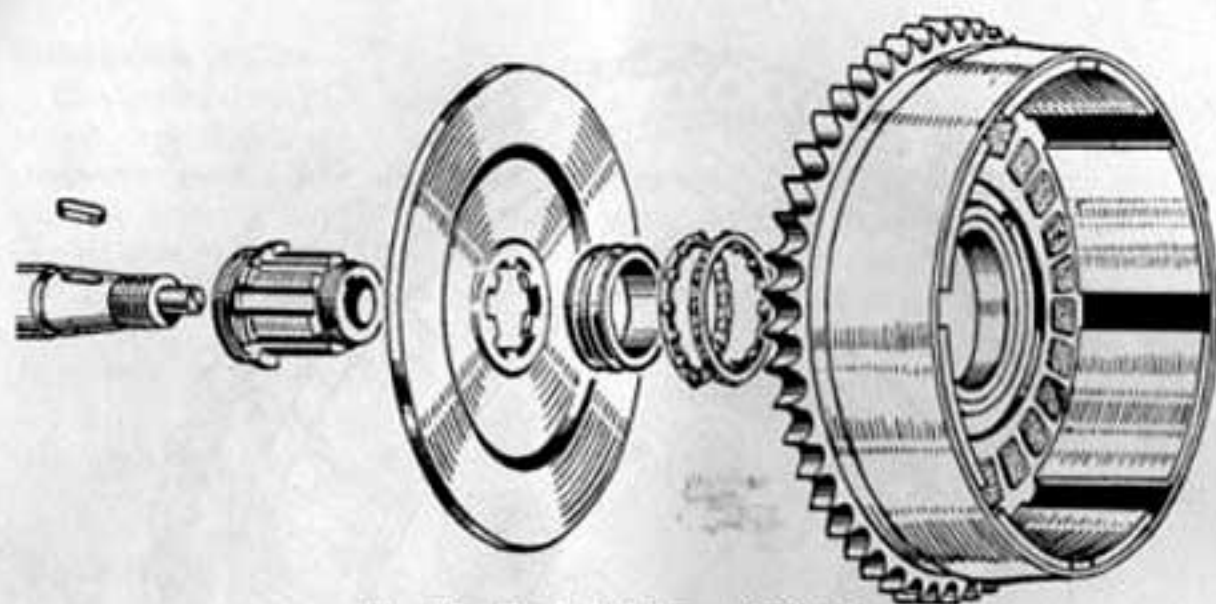

Fig. 15 Exploded View of Clutch.

When topping up with oil, remove the level plug at K (Fig. 12.) and pour oil in the clutch adjustment inspection cover. The oil level must not be above the plug hole, and if the gearbox is overfilled the surplus must be allowed to drain away before the plug is replaced. Removal of the plug L allows all the oil contained in the gearbox to drain out. Whenever possible the gearbox should be drained immediately after a run when the oil is warm. A mineral type of oil should be used, of the same grade as that specified for the engine (see Page 26). The gearbox capacity is 14 fluid ozs. (398 c.c.).

Access to the gearchange and kickstarter mechanism inside the outer cover is simply obtained. Move the gears to neutral then remove the four stud nuts and three screws round the outside edge of the gearbox outer cover. Do not touch the screw and nut which are not on the edge of the cover as these do not prevent its removal. The outer cover will come away complete with kickstarter, gear change and clutch levers. As the cover is withdrawn the kickstarter lever will tend to rotate under the pressure of the spring, and the clutch lever should be used as a stop to prevent the complete release of the spring.

If the gear change mechanism requires attention, remove the gear lever and the small circlip which lies behind it to permit the complete spindle and gear change mechanism to be withdrawn. Examine the operating claw A (Fig. 16) to ensure that the ends of the claw are still well formed. With the outer cover removed the kickstarter spring or any other parts of the kickstarter mechanism can be attended to.

Unless it is necessary to replace the ball bearing carrying the final drive pinion sleeve, the gearbox can be completely dismantled while still in the frame, although the clutch and primary chain case must be removed. If it is necessary to remove the gearbox, both the right hand rear engine plates should be detached. Detach the speedometer and clutch cables. Before the inner cover can be withdrawn the single screw to the left of the top right stud must be undone. The inner cover together with the mainshaft and gearchange rocking lever B can then be withdrawn, leaving the gear cluster in position. If it is required to remove the rocking lever the gearchange spindle bush must first be pushed out of the inner cover, to expose the end of the rocking lever spindle, which is threaded $\frac{1}{4}$ inch B.S.C. Screw in a suitable bolt then use this to pull out the spindle.

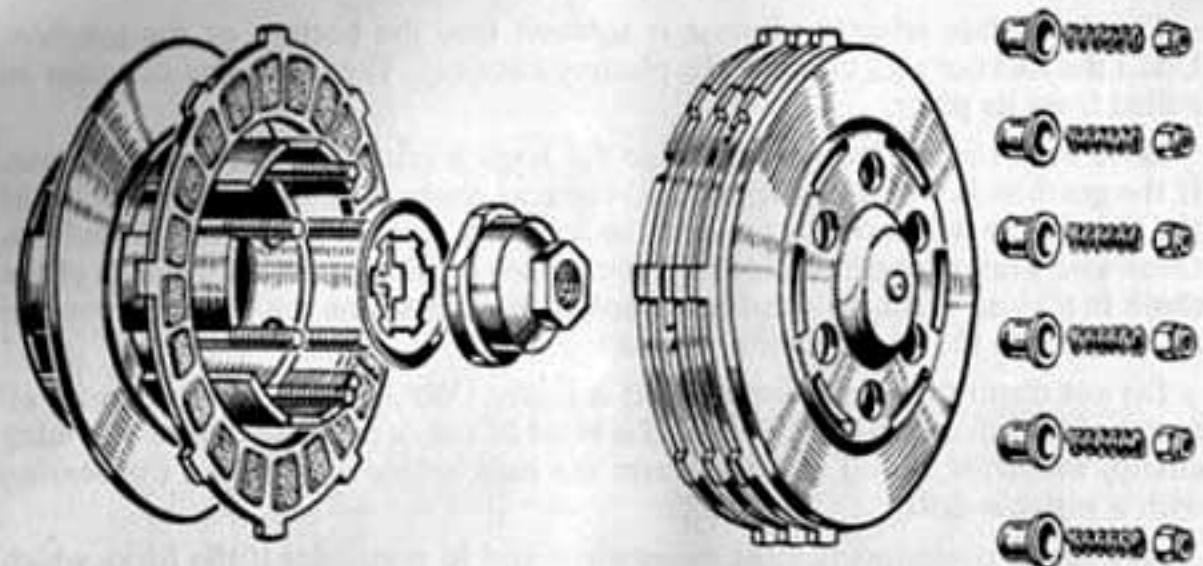

If it is necessary to remove the mainshaft from the inner cover, the shaft should be held in a soft jawed vice so that the kickstart ratchet nut can be undone, after the locking washer has been bent back. The shaft can then be withdrawn from the bearing. This bearing can be removed by pulling out the retaining circlip and then warming the cover in boiling water before pressing or tapping the bearing from its housing with a suitable drift.

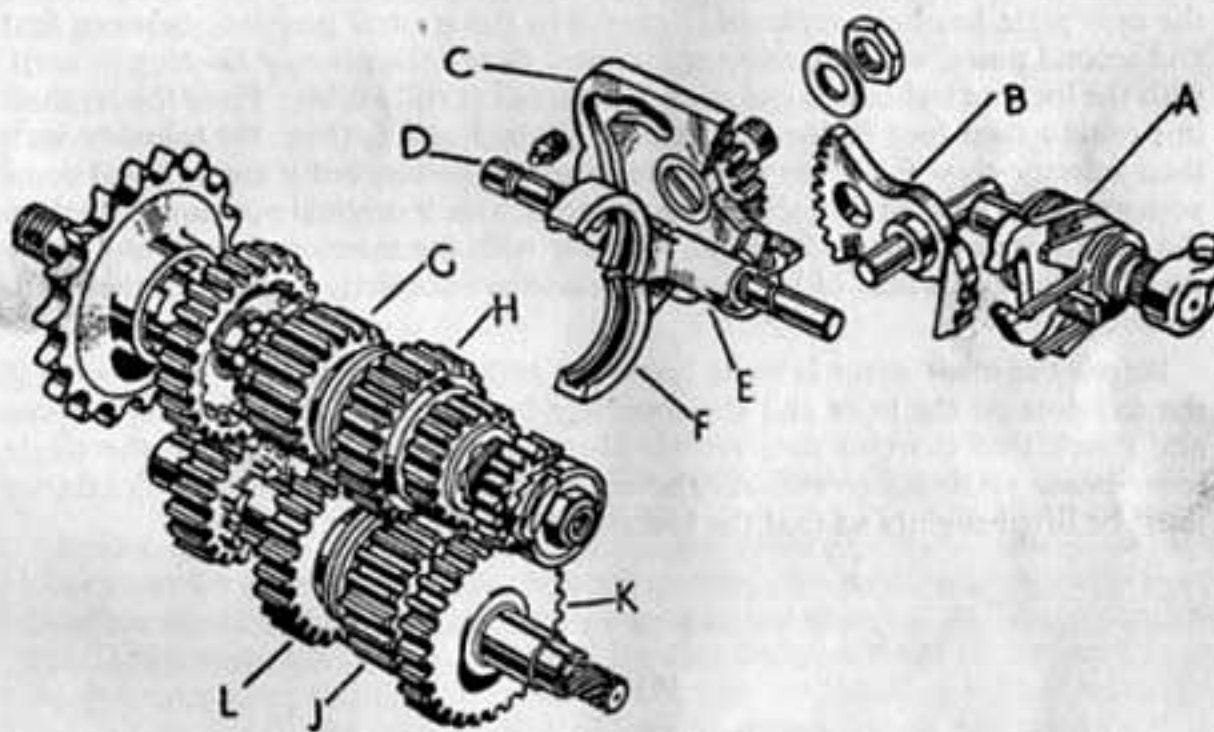

Fig. 16 Gearchange Mechanism.

The rod D, on which the two gear operating claws slide, is pressed into the gearbox shell at the clutch end, and is secured by a small grub screw on the outside of the case. Release the grub screw and pull out the rod. This permits the gear cluster and operating claws together with the layshaft to be withdrawn so that the only components remaining in the gearbox shell are the final drive pinion sleeve and cam plate C.

The cam plate selector plunger is screwed into the bottom of the gearbox. Undo the locknut and unscrew the plunger housing. The cam plate can then be pulled from its pivot.

Bend back the lockwasher and undo the large gearbox sprocket retaining nut. If the gearbox is still in the frame and the rear chain in position, application of the rear brake will serve to prevent the sprocket turning as the nut is undone. Otherwise wrap a length of old chain round the sprocket and hold the ends of the chain in a vice. With the sprocket removed from its spline the pinion sleeve can be driven into the gearbox with a mallet.

Do not disturb the ball race unless it is faulty. Wash it in petrol to remove all traces of oil before testing for play. If it must be removed, prise out the retaining circlip, withdraw the oil seal and warm the case before tapping out the bearing with a suitable drift.

Any faulty components must be renewed and in particular if the forks which operate the sliding pinions show signs of seizure they must be replaced.

Re-assembly.

If new gears are to be fitted make sure that the fixed pinions on the layshaft and mainshaft are a tight fit, and that they are pressed right up to their locating circlips.

Re-assembly generally is carried out in the reverse order to dismantling. When the cam plate has been replaced, locate it in the neutral position, between first and second gears, with the selector plunger. Screw the plunger housing in until, with the locknut tightened, one complete thread is still visible. Place the layshaft in position then feed in the first pair of gears J and L (Fig. 16) together with their selector claw F. These claws are interchangeable, but if the original components are to be used they should be replaced in their original positions. Replace the second pair of gears G and H, together with the selector claw E, and make sure that the guide pins of both selector claws are correctly engaged in their cam grooves.

Before the inner cover is quite home the rocking lever B must be set so that the red dots on the lever and the cover are in line. Push the cover right home and check that the two dots remain correctly positioned. Replace the single inner cover retaining screw. As the outer cover is pushed on, the kickstarter must be lifted slightly so that the kickstarter quadrant can engage.

WHEELS

Both wheels are fitted with ball journal bearings and adjustment is not necessary. These bearings are packed with grease during assembly which will last until the machine is in need of a complete overhaul.

Brake Adjustment.

This will give a setting for maximum efficiency with the shoes just clear of the drum when the brake is off, and close enough for immediate contact when the brake is applied. Note: that if the brakes are adjusted too closely, i.e. that they should rub, the heat generated may distort the brake drum and melt the grease in the hub.

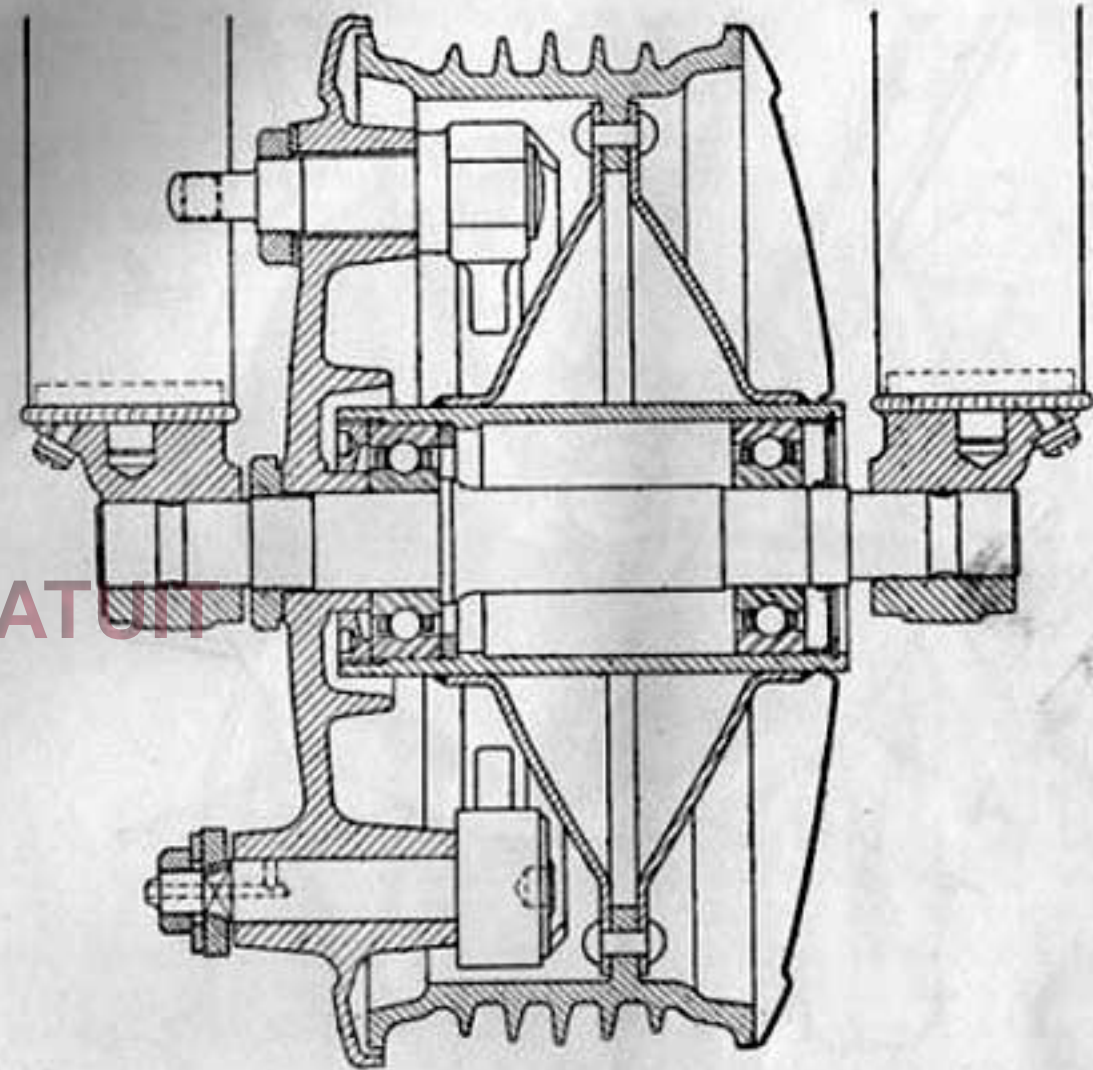

Fig. 17 Front Hub Arrangement.

The Rear Cross-over Shaft.

The rear brake cross-over shaft is smeared with grease during assembly, and after a considerable mileage it should be removed and re-greased.

Before the cross shaft can be removed, the brake pedal and the cross shaft lever must be disconnected. Slacken the pinch bolts, and pull the levers away from the shaft, noting their respective positions for re-assembly. If this instruction is not observed there is a possibility that the levers will be replaced in an incorrect position, causing the brake to function inefficiently. When this operation is completed, the cross-over shaft can be pulled out of the swinging arm. The shaft should then be wiped clean, smeared with new grease and re-assembled.

Front Wheel Removal.

To remove the front wheel from the forks, disconnect the brake cable, then remove the four bolts A, Fig. 18. The wheel can be pulled away from the machine.

The wheel is replaced in the reverse order to that for removal. It is most important that the brake anchorage peg on the right hand fork leg should engage correctly in the slot in the cover plate.

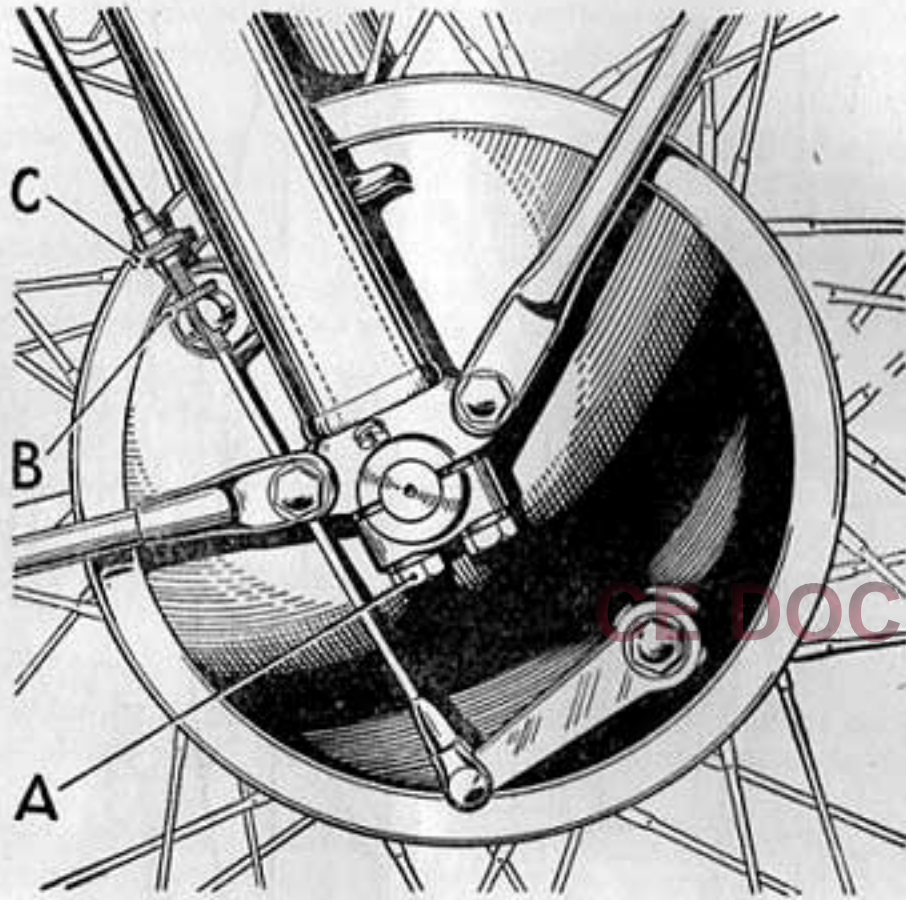

Fig. 18 Front Wheel Removal.

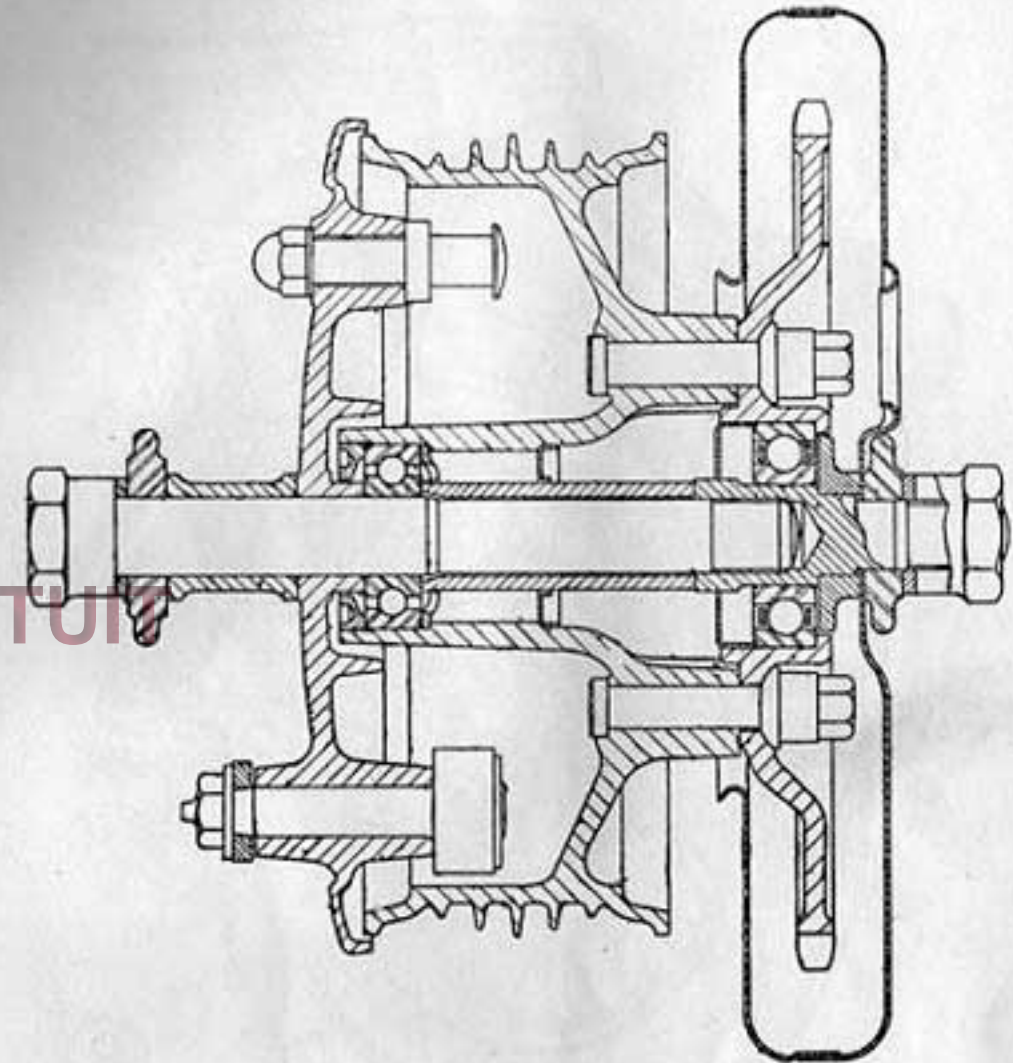

Fig. 19 Rear Hub Arrangement.

Rear Wheel Removal and Replacement.

To remove the rear wheel, place the machine on its stand. Take off the nut A. (Fig. 20), to free the brake anchor strap; and disconnect the brake cable. Unscrew the four retaining nuts B (Fig. 21), locking the wheel on the chainwheel. On machines fitted with a fully enclosed chainguard, this operation is carried out after removing the rubber plug D (Fig. 21). Next, place a spanner on to the spindle end at B (Fig. 20), and unscrew in an anti-clockwise direction until it can be withdrawn. The distance piece C can then be removed and the wheel can be withdrawn to the right, when it can be taken out downwards and rearwards. Note that the large nut A (Fig. 21) on the left-hand edge of the spindle retains the chainwheel and should not be disturbed.

Re-assembly is carried out in the reverse order, but it is most important that the four retaining nuts are screwed up tight when the wheel is replaced.

Rear Chain Adjustment.

The rear chain must be adjusted when the machine is on its stand and the wheel is at the lowest point in the suspension. Rotate the wheel slowly until the tightest point on the chain is found, then check its up and down movement in

the centre of the chain run. On machines fitted with a fully enclosed chainguard the rubber plug C (Fig. 21) should be removed to test the chain tension. The total movement should be $1\frac{1}{4}$ inches and if it varies from this setting then the chain must be adjusted by moving the rear wheel. Unscrew the spindle B, (Fig. 19) slightly, then slacken off the hexagon A (Fig. 21) on the left-hand side of the hub. Release the locknuts D and screw the adjusters E in or out as the case may be, until the chain tension is correct.

Wheel Alignment.

It is advisable to check the wheel alignment whenever the rear chain is adjusted, although if it is known that the previous adjustment was satisfactory and the adjuster nuts E are moved by an equal amount, then the alignment should remain correct. The wheel alignment can be checked by glancing along the line of both wheels when the front wheel is set straight, or by means of a long straight edge placed along the sides of the wheels, but it must be remembered that the edge must be stepped to suit the difference in tyre sizes between front and rear wheels. Apply the straight edge at a point immediately below the silencers and keep in a horizontal position. With the front wheel set straight ahead, the straight edge should touch both wheels.

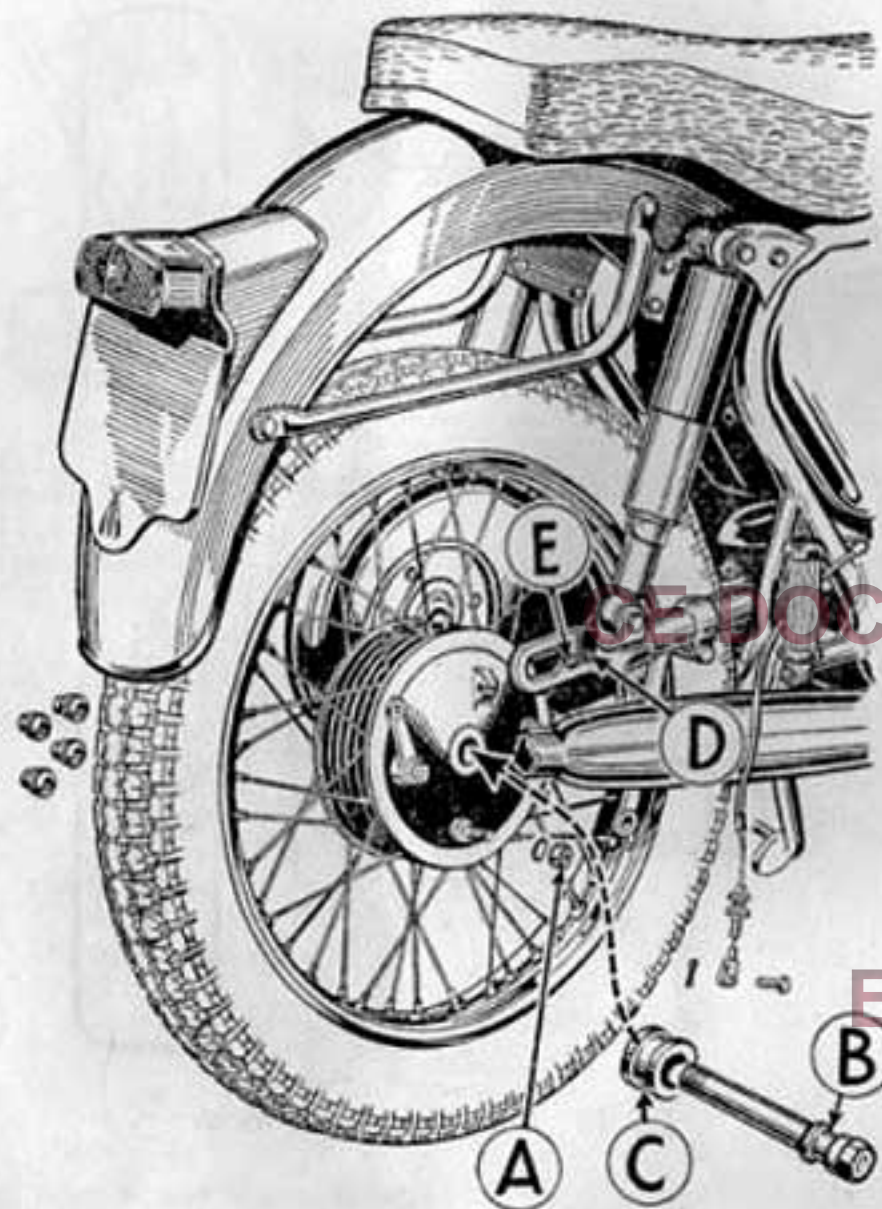

Fig. 20 Rear Wheel Removal.

Brake Shoe Removal and Replacement.

Slacken the brake shoe adjuster fully, and remove the brake plate from the wheel. Then grasp the shoes firmly, pulling outwards enabling the shoes to clear the fulcrums and lift. Both shoes will then come away from the brake cover plate.

The shoes can be replaced by the reverse procedure. Hook the springs on to the shoes and place the ends of the shoes in position on the fulcrum pins, pushing the shoes outwards until the springs pull them into their correct position.

Note: The brake shoe springs are quite strong and care should be taken that the fingers are not trapped by the brake shoes during these operations.

Brake Shoe Re-lining.

With the shoes removed the linings can best be removed by drilling away the heads of the rivets and punching the shanks out to the inside of the shoe with a suitable punch.

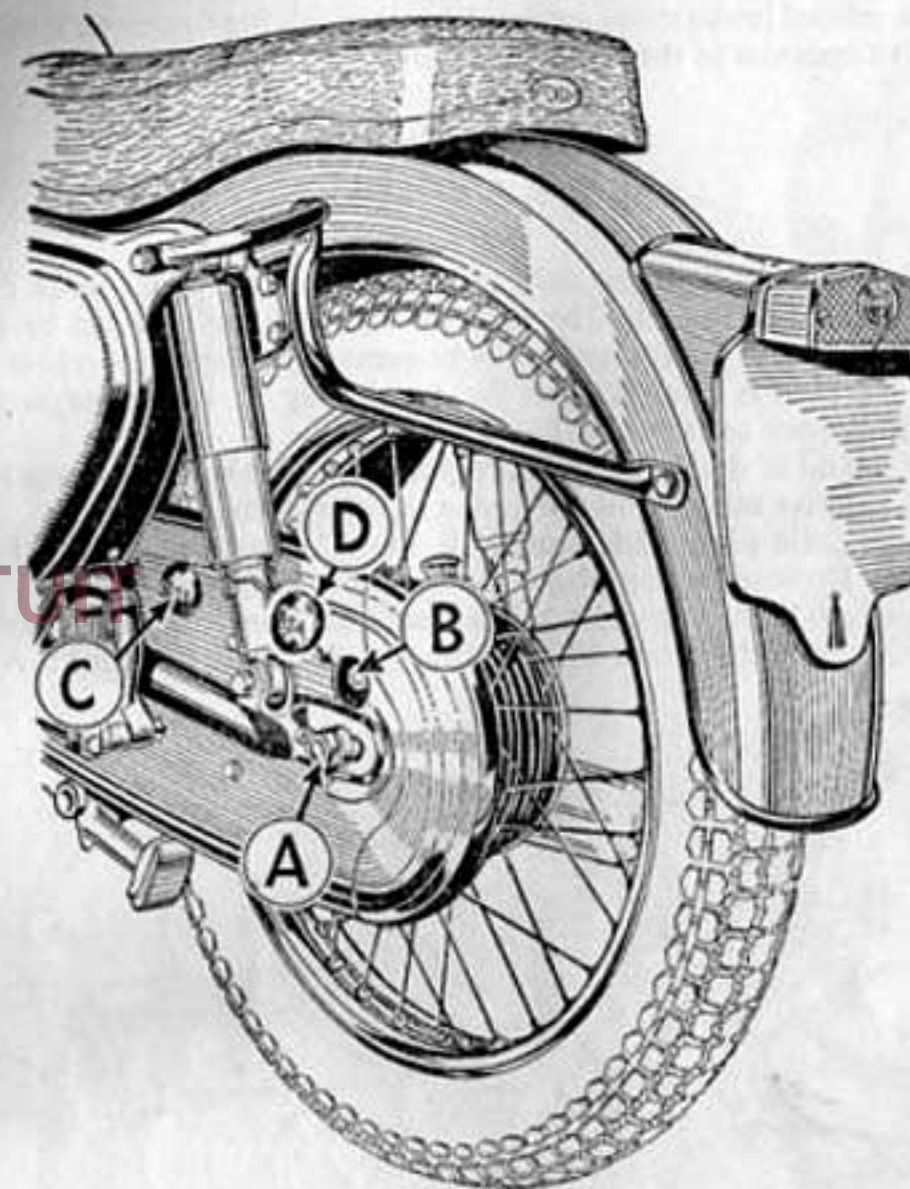

Fig. 21.

New linings are die pressed to suit the curvature of the shoes, but will require drilling and counter-boring for the rivets. Position the lining and hold it in place at one end by means of clamps. Using the holes in the shoes as guides, drill holes of the correct size for the rivets adjacent to the clamp. Turn the shoe over and counter-bore the holes just drilled deep enough to allow the rivet heads to stand below the lining surface; this is important, since the rivets will otherwise score the brake drum.

Insert the rivets into the holes and rivet them over on the inside of the shoe. This is easily accomplished by holding in a vice a short length of rod, whose diameter is equal to that of the rivet head and using it as an anvil upon which to rest the rivet head while hammering the shank over. This will make sure also that the rivets do not stand proud of the lining.

Move the clamps to the next pair of holes, taking care that the lining is kept in firm contact with the shoe the whole time, and repeat the above procedure. When the lining is finally riveted down, bevel off the ends of the linings and file off any local high spots.

Complete relined brake shoes are available through the Exchange Replacement service which operates in the British Isles only.

FRAME AND FORKS

Front Forks.

Under normal conditions the only servicing which the front forks require is occasional renewal of the oil. The need for this may be indicated by excessive movement of the forks but it should only be necessary after considerable mileage.

Remove the plug A (Fig. 22) and the drain plug in the lower end of the fork sliding member as shown in Fig. 18).

Allow all the oil to drain out, then apply the front brake and depress the forks a few times to drive out any oil remaining in the system.

Replace the drain plugs and pour $7\frac{1}{2}$ fl. ozs. (213 c.c.) of an S.A.E. 20 oil into each leg. Replace the top plug and tighten it firmly.

The following oils are recommended for use in the front forks: Mobiloil Arctic, Shell X100-20, Castrolite, Esso 20, B.P. Energol S.A.E.20, Haveline S.A.E.20W.

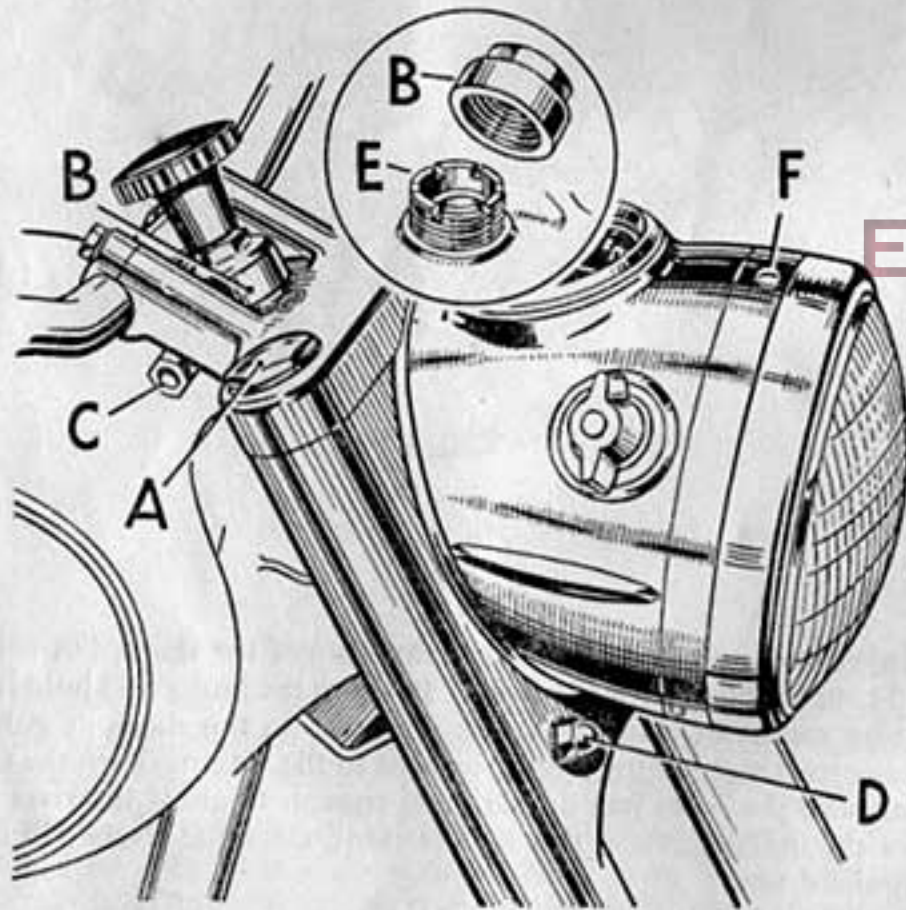

Fig. 22 Front Fork and Steering Head.

Steering Head Adjustment.

The steering head should be tested occasionally for play and to ensure that it rotates freely. Support the crankcase on a box so that the front wheel is clear of the ground, then grasp the front fork legs and attempt to push them backwards and forwards. If any play is detected the steering head must be adjusted.

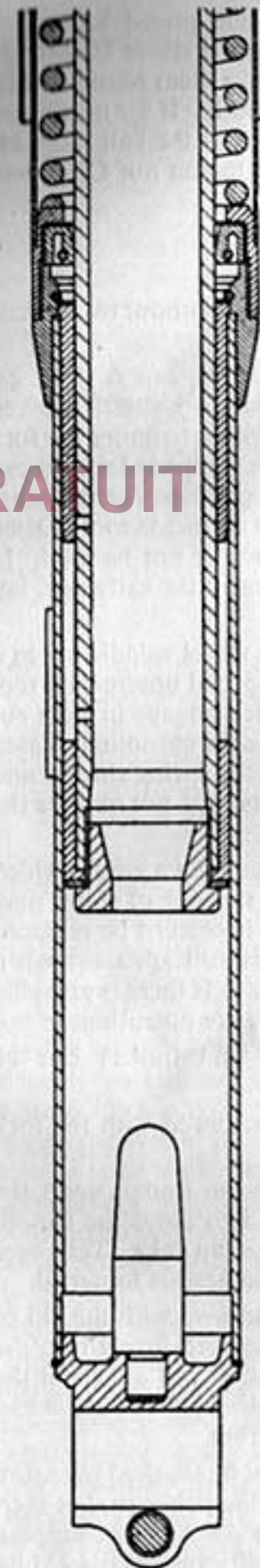

Fig. 23 Fork Section.

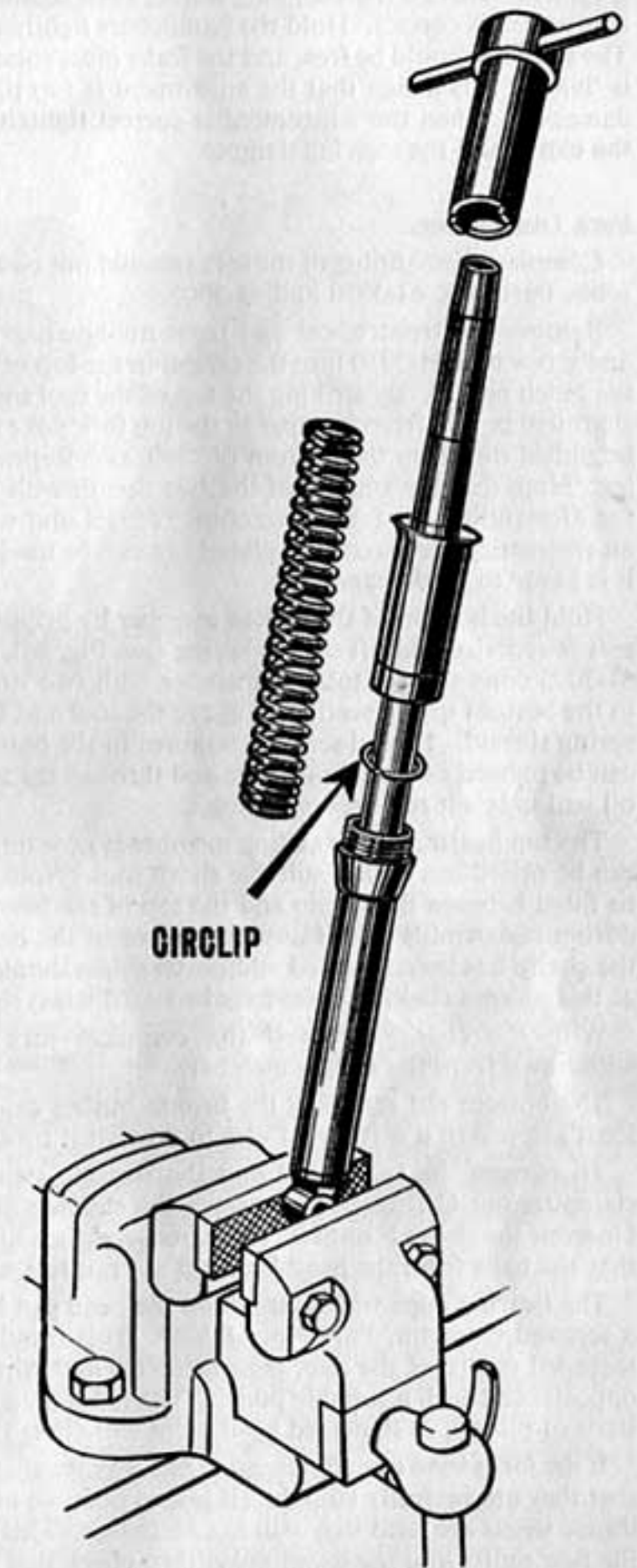

Fig. 24 Fork Dismantling.

Unscrew the steering damper and remove the chromium plated top cap B (Fig. 22). Slacken the clamping nut C, then tighten down the sleeve E until the adjustment is correct. Hold the handlebars lightly and move them round slowly. The steering should be free, and the forks must rotate smoothly. If the movement is 'lumpy' it is a sign that the adjustment is too tight, or that the ball races are damaged. When the adjustment is correct tighten the clamping nut C, replace the cap B and the steering damper.

Fork Dismantling.

Complete dismantling of the forks should not be attempted without two special tools, Part Nos. 61-3350 and 61-3005.

Remove the front wheel and front mudguard. Remove the cap A (Fig. 22) and screw tool 61-3350 into the thread in the top of the main fork shaft. Slacken the pinch bolt D. By striking the top of the tool smartly with a hammer the fork shaft will be free from its taper in the top fork yoke and the complete fork leg can be pulled out from the bottom of the fork. Repeat the operation for the other leg. Note that the smaller of the two fine threads on the extractor tool is used for dismantling the forks on another model and will therefore not be used. In an emergency the chromium plated cap can be used in place of the extractor, but it is likely to be damaged.

Hold the bottom of the sliding member by gripping the wheel spindle lug in a soft jawed vice and lift off the spring (see Fig. 24). The special unscrewing tool 61-3005 consists of a tubular member with two dogs which engage in slots cut in the bottom spring seating. Engage the tool and unscrew the chromium plated spring shroud. The oil seal is contained in the bottom of the spring shroud and can be pressed out with a drift passed through the two slots. Do not remove the oil seal unless it requires replacing.

The top bearing of the sliding member is now retained only by a circlip which can be prised out with a suitable sharp tool. Note that a number of shims may be fitted between the circlip and the top of the bearing. These must be replaced during re-assembly and if any movement of the bearing is still apparent when the circlip has been replaced additional shims should be used. If there is any play at this point a clicking noise may be heard when the forks are operating.

With the circlip removed the complete fork shaft and bushes can be withdrawn from the sliding member.

The bottom nut retaining the bronze bushes can be unscrewed with the fork shaft gripped in a soft jawed vice to prevent it turning.

To remove the two yokes and the steering stem from the frame, undo the clamping nut C (Fig. 25). Remove the steering damper knob and the cap B. Unscrew the sleeve E until it comes free, and then lift off the top yoke. Take care that the balls from the head bearings are not lost when the head is loosened.

The bearing cups which remain in the head can be withdrawn with the aid of a screwed extractor, Part No. 61-3063. This should be screwed firmly into the threaded centre of the cup, then extractor and cup can be driven out from the opposite end with a suitable punch. The races must be replaced if they show any signs of pitting, as damaged head races will affect the steering.

If the forks have been damaged in any way the shafts must be checked to ensure that they are perfectly straight. It is also possible to twist the yokes so that even if new shafts are used they will not be in line. This can be checked by clamping the new shafts into the lower yoke, then check that the shafts are not twisted by placing them on a surface plate or on two parallel straight edges. Also check that

when the top yoke is slid down the head stem sleeve on to the shafts, the tapers meet squarely. If they are only slightly twisted it is possible to reset the yokes, but replacements are preferable.

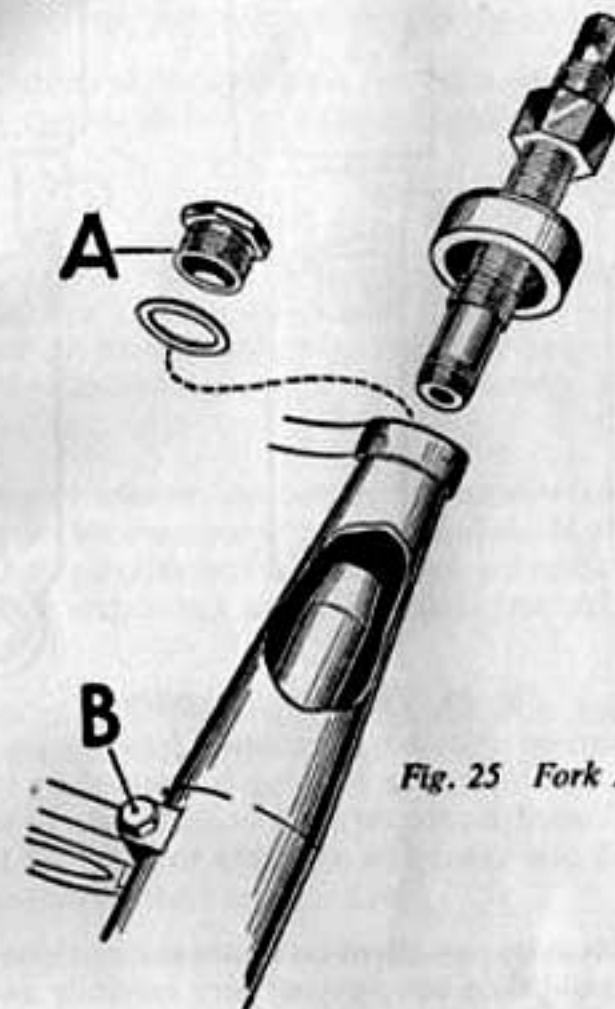

Fig. 25 Fork Assembly.

Re-assembly is carried out in the reverse order to dismantling. Make sure the oil seal lip is facing downwards. Before screwing down the oil seal holder pass one turn of medium twine round the undercut at the base of the thread to provide an additional seal. When replacing the legs pass the main fork shaft up through the bottom yoke as far as it will go, then pass the tool 61-3350 down through the top yoke and screw it into the top of the shaft (Fig. 25). Do up the nut on the tool to pull the shaft up into the top yoke. Tighten the clamp in the bottom yoke while the tool is removed and the top plug replaced. Slacken the lower clamp, tighten the top plug firmly, then do up the clamp again. Alternatively, in an emergency, a suitable sized length of wood, cut to a taper at the end, can be screwed into the top of the shaft.

Rear Suspension.

The two suspension units comprise a telescopic damper unit and a totally enclosed coil spring. The pressure on the spring can be varied by means of a three position cam adjuster (Fig. 26) at the lower end of the unit. The springs can therefore be adjusted to suit the load conditions or nature of the ground. A 'C' spanner in the tool kit is used to rotate the cam ring.

The hydraulic dampers require no attention whatsoever. They are sealed during manufacture and if they suffer damage or become ineffective they must be replaced.

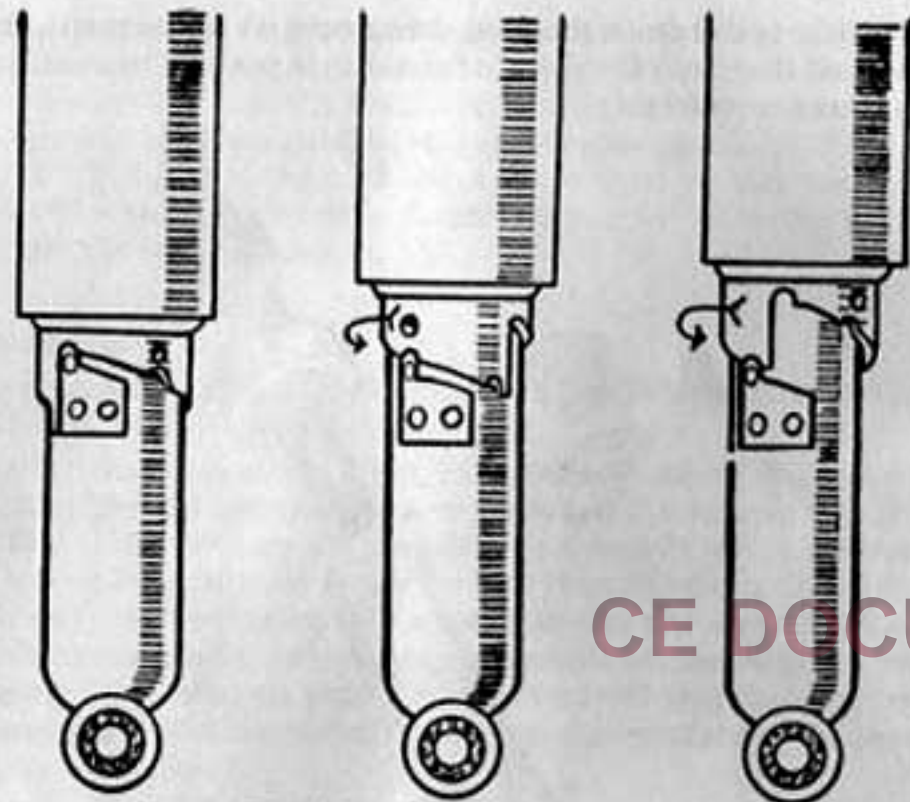

Fig. 26 The Rear Suspension.

The complete suspension units can be removed from the frame after detaching the two pivot bolts. The top spring housing is retained by two collets and the spring must be compressed before they can be removed. In some instances, the assistance of a second person may be necessary to compress the spring.

Frame.

The frame will not require any attention unless the machine has been involved in an accident. It should then be inspected very carefully and the wheel alignment checked. If the frame is damaged or distorted it must be replaced, or submitted to your B.S.A. dealer for rectification if feasible.

To remove the rear swinging arm from the frame front, detach the rear brake cross shaft lever (see Page 35), remove the suspension units, the rear wheel complete and the rear chain guard. Then undo the nut on the end of the fulcrum spindle and the bolt which locates its steel end plate. The spindle can then be tapped out with the aid of a suitable punch. As the spindle is hollow, care must be taken, as its inside bore may be burred. Move the fork forward until it is free of the side plates, so that it can be twisted and pulled away to the rear.

The rear arm silentbloc bushes have a very long life, and replacement will rarely be necessary.

The swinging arm cross tube is counter-bored at each end to accept the bushes so that it is not possible to tap them right through the tube. In order to effect their removal, tap the inner alloy portion of the bearing with an $\frac{1}{8}$ inch B.S.F. tap and screw in a suitable bolt. The complete bearing can then be tapped out from the other end of the tube with the aid of a long punch.

Replacement bushes should be pressed in until their inner tubes meet at the centre. Ensure that the inner tubes project by an equal amount at each end of the swinging arm cross tube.

Re-assembly of the swinging arm into the frame is carried out in the reverse order to that for dismantling, but the final tightening of the spindle nut should be left until all the other items have been replaced. Load the machine until the rear suspension is in the centre of its travel, then tighten the spindle

nut firmly. This procedure ensures that the bush centres are clamped into the correct position.

ELECTRICAL EQUIPMENT

The electrical equipment fitted requires very little attention, but the few instructions given in this chapter should be followed carefully to provide maximum life and reliability.

Battery.

Access to the battery is obtained by removing the two retaining bolts under the rear of the dual seat so that the seat can be lifted and pulled away to the rear. Remove the two small bolts securing the top strap to gain access to the top of the battery, and by merely unscrewing the two battery terminals the battery is left free to be lifted out.

About once a month take off the battery lid, remove the filler plugs from each of the cells and examine the level of the electrolyte. If necessary add sufficient distilled water to bring the level of the electrolyte up to the top of the separators. Do not use tap water and do not use a naked light when examining the condition of the cells.

The condition of the battery should occasionally be checked by taking hydrometer reading of the specific gravity of the electrolyte.

If distilled water has been added a reading should not be taken until after the machine has been used, to ensure that the electrolyte is thoroughly mixed. The specific gravity readings should be as follows:

Temp.	Fully Charged	Requires Charging
120°F	1.270	1.220
100°F	1.280	1.230
80°F	1.285	1.235
60°F	1.295	1.245
40°F	1.305	1.255
20°F	1.310	1.260
0°F	1.320	1.270
-20°F	1.325	1.275

Handwritten notes on the table: 32°C is aligned with 90°F; 15°C is aligned with 60°F; 0°C is aligned with 32°F.

The reading for each of the three cells should be approximately the same. If one cell gives a reading very different from the other it may be that the electrolyte has been spilled or has leaked from this particular cell or there may be a short circuit between the plates. If leakage from the top of the battery is known to have occurred, due to a spill, the battery should be topped up with battery acid of suitable specific gravity.

Never leave the battery in a discharged condition as it will suffer permanent damage. Keep the top of the battery clean and smear the terminals with vaseline to prevent corrosion.

All models employ a positive earth wiring system. Make sure that the battery is connected correctly.

Dynamo.

The two brush dynamo is coupled to a cut-out and regulator unit fitted inside the toolbox. The regulator varies the output of the dynamo to match the lighting load and the state of charge of the battery. When the battery is in good condition the charge rate will be only one or two amps. A discharge reading may sometimes be observed immediately after switching on the lights, but as soon as the battery voltage falls the regulator causes the dynamo output to balance the load.

About every 10,000 miles, take off the cover band and check the brushes and commutator. See that the brushes move freely in their holders by holding back the brush springs and pulling gently on the flexible connectors. If a brush is inclined to stick, remove it from its holder and clean the sides with a petrol moistened cloth. Be careful to replace the brushes in their original positions in order to retain bedding.

The commutator should be clean, free from oil or dirt and should have a polished appearance. If it is dirty, clean with a dry duster while the engine is rotated slowly. If the commutator is very dirty, moisten the cloth with petrol.

The armature is mounted on ball bearings which are packed with high melting point grease during initial assembly. This grease will last until the machine is in need of a complete overhaul, and no other lubrication is required.

Electric Horn.

The horn is adjusted at the works to give its best performance and will give a long period of service without any attention. If it becomes uncertain in action, giving only a choking sound, or does not vibrate, it does not follow that it has broken down. First ascertain that the trouble is not due to some outside source such as a discharged battery, or a loose connection or short circuit in the wiring.

If none of the previous suggestions proves successful, the horn may be re-adjusted as follows:

Turn the adjusting screw in the rear of the horn body slightly to left or right while depressing the horn button until the best note is obtained.

If the horn still gives trouble it should be removed and returned to the manufacturers.

Headlamp.

The headlamp is of the sealed unit type employing a pre-focus bulb. To gain access to the bulbs, the headlamp rim complete with light unit must be removed by slackening the screw on top of the headlamp shell and pulling the rim away at the top. The headlamp bulb is retained by a bayonet fitting cap. Push on the cap, turn it to the left, and then withdraw. The bulb is located by a flange which has a notch engaging with a projection inside the holder to ensure that it is correctly positioned. Note that the prongs of the bayonet fitting cap are not symmetrical so that it can only be replaced in the correct position.

The headlamp requires no maintenance except to ensure that the contacts are kept clean and tight. The reflector is sealed to the glass and in the event of either becoming damaged the complete unit must be replaced.

The best way to obtain the initial setting of the main headlamp beam is to stand the machine about 25 feet away from a wall and move the headlamp until the beam is parallel to the ground and strikes the wall at the same height off the ground as the centre of the headlamp. A final check should be made on the road

to ensure that the beam strikes the road as far away as possible but in no circumstances must the beam point above the horizontal.

Stop Light Switch.

This is operated by the brake pedal through a spring. Keep the switch free from grit and water and occasionally apply a little thin oil to the operating mechanism.

Tail Lamp.

Access to the tail lamp is obtained by removing the two screws securing the red transparent plastic cover. Note that the locating prongs of the bulb are offset so that it can only be replaced one way round.

Bulbs.

The correct replacement bulbs are as follows:

Head	<i>PHARE.. CODE</i>	..	Lucas No. 312	30/24 watts.
Pilot	<i>v. 2.5 watts</i>	..	Lucas No. 988	3 watts.
Stop/Tail	<i>Per arrive.. Stop</i>	..	Lucas No. 384	6/18 watts.
Speedometer	<i>comp. ten</i>	..		6.5 v. .3 amp.

Circuit Diagram.

A diagram of the charging and lighting circuits appear from Pages 49 to 53. The insulation of the wires is individually coloured and these colours are shown on the diagram.

Renewing High Tension Cable.

If the high tension cables show signs of cracking or perishing they must be replaced by 7 m.m. rubber covered ignition cable. To make the connection to the pick up terminals, thread the moulded terminal nuts over the cables for about quarter inch, thread the wire through the washers removed from the original

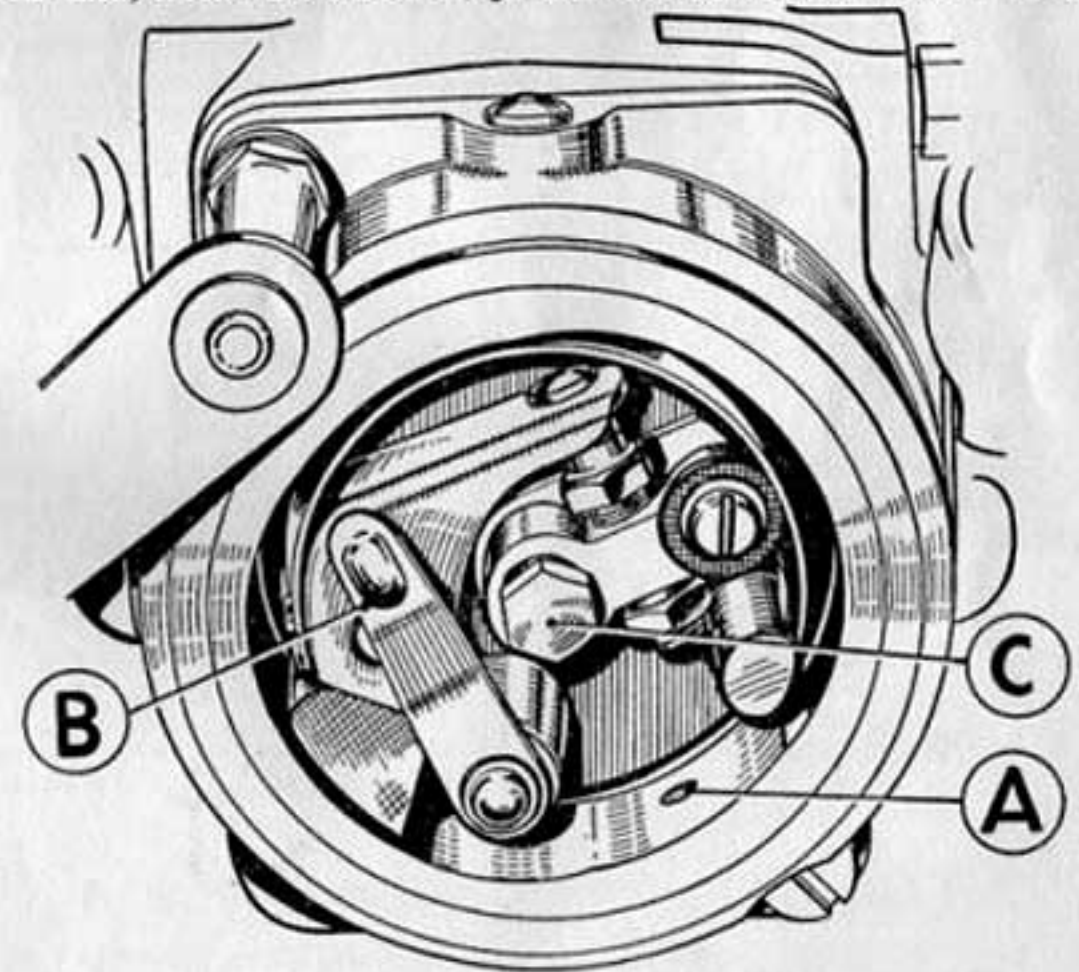

Fig. 27 Magneto Contact Breaker.

cables and bend back the wire strands. Screw the nuts back into their respective terminals.

Magneto.

The cam ring is lubricated from a felt pad set in the bottom of the ring. Every 3,000—4,000 miles apply a few drops of thin machine oil through the hole at A Fig. 27, in the lower edge of the cam ring.

Examine the contact breaker points and if they are burned or blackened, clean the contacts with fine emery cloth or carborundum stone. Before the contact breaker rocker arm can be detached the contact breaker body must be removed from the armature body. Undo the central bolt C and grip the central boss firmly with a pair of pliers. A sharp tug will free the body from its taper. Move aside the spring clip B which retains the contact breaker arm and remove the screw which holds its spring to the body. The rocker can then be pulled from its shaft. Ensure that everything is perfectly clean before re-assembly.

CE DOCUMENT EST GRATUIT

ET NE PEUT

EN AUCUN CAS

ÊTRE VENDU

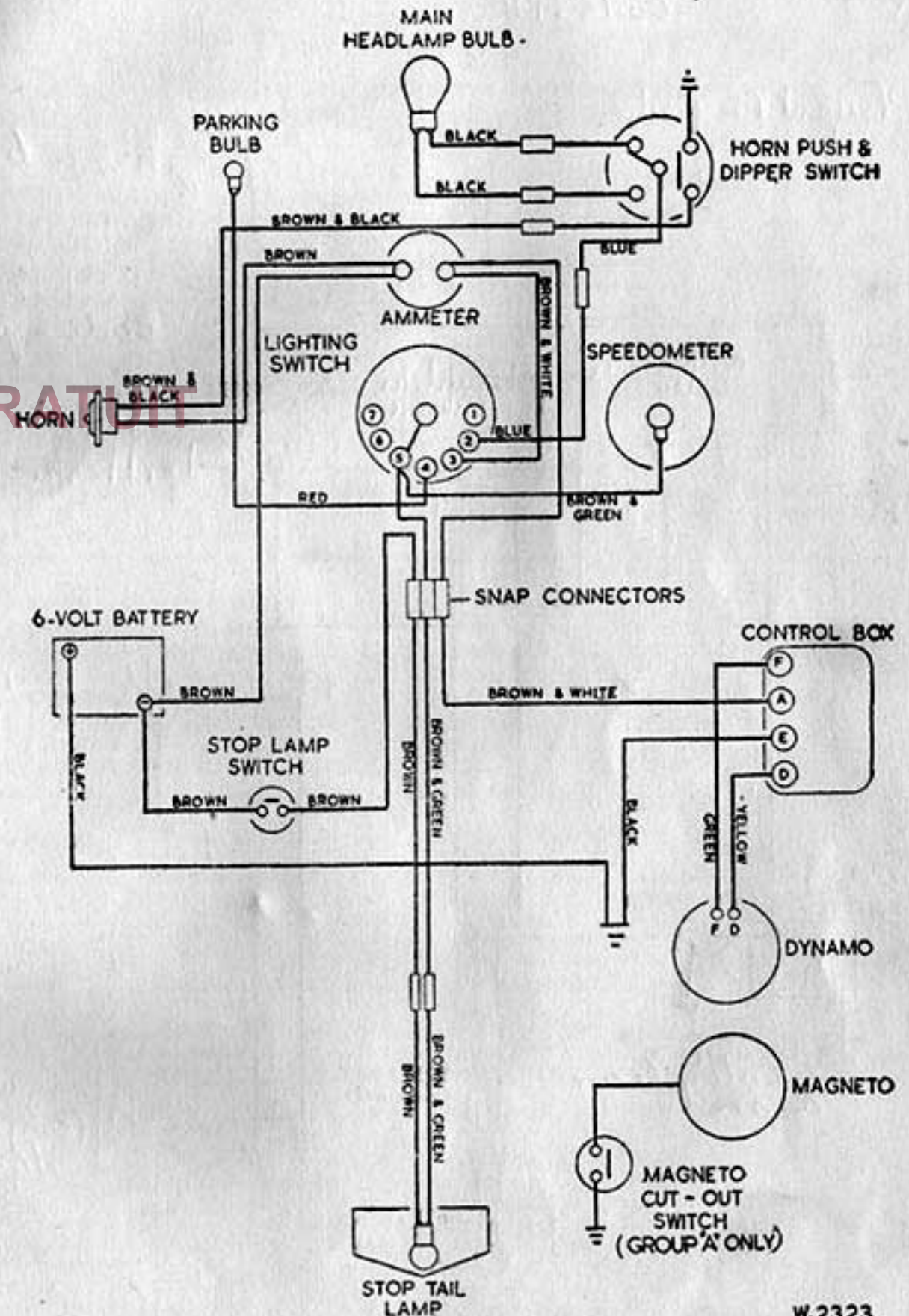

Fig. 28. Wiring Diagram (A7, A7 S.S., A10 models with cowl).

W.2323

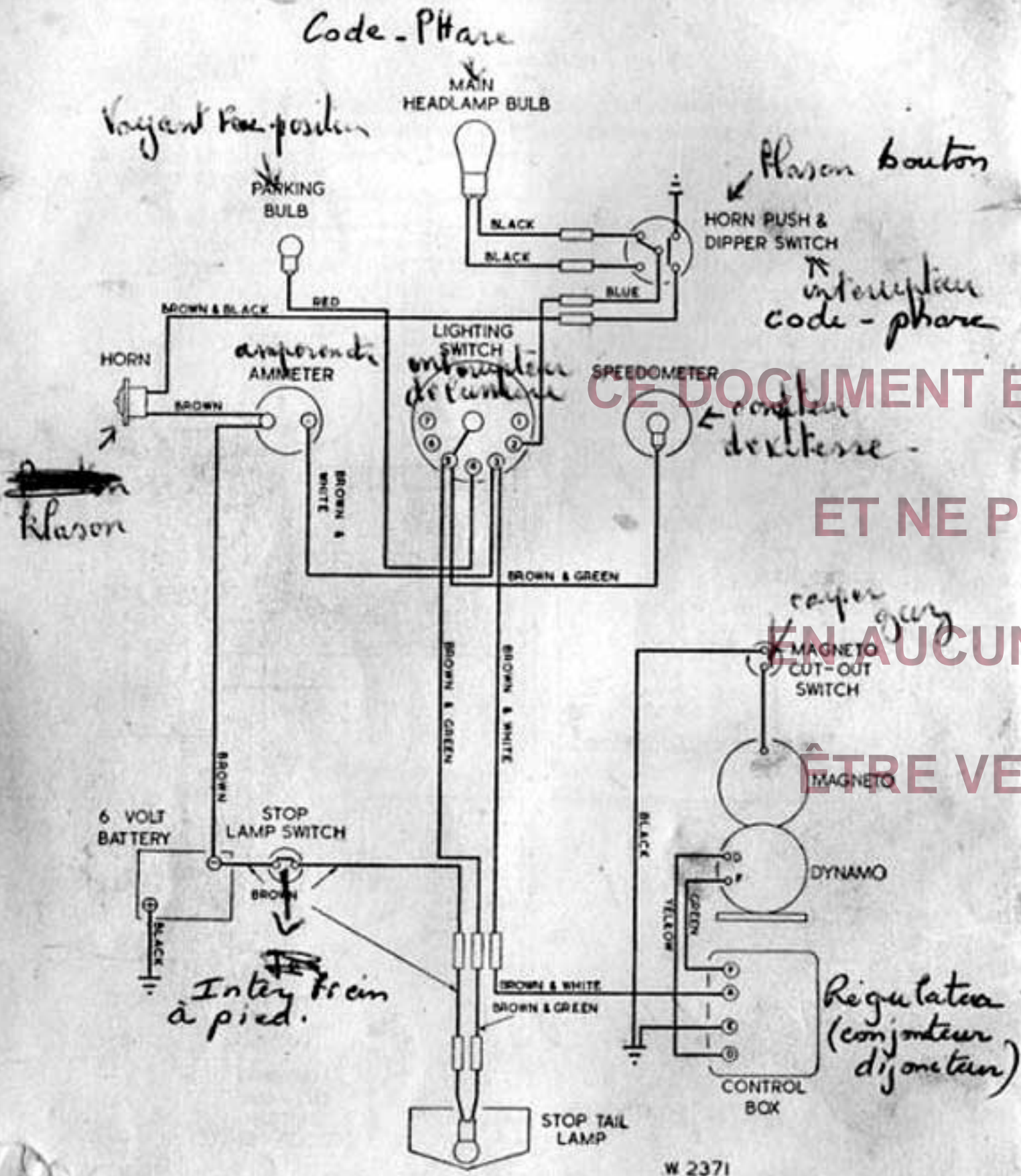

Fig. 29. Wiring Diagram (A10 Super Rocket)
(Fitted to models without cowl)

B.S.A. MOTOR CYCLE SPARES STOCKISTS



Save time and postage by contacting your nearest B.S.A. Stockist for B.S.A. Spare Parts, Spare Parts Catalogues, Instruction Books, Transfers, etc.

All B.S.A. Dealers carry stocks of B.S.A. Spare Parts but the following appointed Stockists maintain a comprehensive range.

Town	Name of Stockist	Address	Telephone No.	Telegraphic Address
Aberdeen	J. Dawson	24-26 Thistle Street	25556	
"	George Cheyne (Cycles) Ltd.	147/149 Holburn St.	50341/2	Motobike, Aberdeen.
Aberystwyth	Gwalia Motor Co.	North Parade	525	
Accrington	Bill Snape Ltd.	379 Blackburn Road	4724	
Aldershot	Phillips Bros. (Aldershot) Ltd.	Birchett Road	1111/2	Phillips, Cycles, Aldershot.
Alloa	J. G. Robertson	55-57 High Street	193	
Andover	Corbett & Ellis (Andover) Ltd.	Weyhill Road	2991	
Ashington	Mains of Ashington	Laburnum Terrace	3204	
Aylesbury	Eborn's Garage	44 Walton Street	3150	Eborn's, Aylesbury
Banbury	Trinder Bros.	2 & 3 Broad Street	2546	
Barnsley	T. Garner & Son	Sheffield Road	2866	
Barnstaple	Bob Ray Ltd.	43 High Street	4266	
Bath	R. U. Holway & Son	32-33-34 St. John's Rd., Bathwick	5084/64101	
Bedford	The Imperial Cycle Co.	58 St. Loyaes	2374	
Belfast	W. J. Chambers & Co.	106 and 108 Donegall Pass	27253/4	Fastmote, Belfast.
Biggleswade	Bryants	25, 27, 72 and 74 Shortmead Street	3108	
Birkenhead	Bob Simister Ltd.	540 New Chester Rd., Rock Ferry	Rock Ferry 1452	
Birmingham	County Cycle & Motor Co. Ltd.	266 Broad Street	Mid. 2671	
"	C. E. Cope & Sons Ltd.	104 Bath Row (Repairs) (closed Saturday 1 p.m.)	Mid. 2817	
"	Shovelbottom's Ltd.	481-487 Hagley Road, Edgbaston 17	Bearwood 2246/7	
"	Aston Auto Motors	376 Ladypool Road, Sparkbrook 12	South 2212	
"		172 Aston Road 6	Aston Cross 3201/2	
Blackburn	S. & G. Motor Cycles (Blackburn) Ltd.	15-17 Great Bolton St.	6678	
Blackpool	J. Hall & Son	102-6 Devonshire Rd.	22130	
Blandford	Badger Garages Ltd.	Salisbury Road	615	
Bolton	Charlie Robinson	119 and 121 Higher Bridge Street	3931	
Boscombe, Bournemouth	Craze Bros.	473 and 475 Christchurch Road	Boscombe 33231/2	
Bradford	C. Sidney Ltd.	107 Manningham Lane	29889	
"	J. K. Hurst	41 Wakefield Road	22543	
Bridgwater	Anderson & Wall	18 St. Mary Street	2416	Anderson & Wall, Bridgwater
Brighton	Redhill Motors (Brighton) Ltd.	104 North Road	5281	
Bristol	S. J. Fair Motors Ltd.	201-3 Cheltenham Rd.	4-6238/4-1015	

B.S.A. Motor Cycle Spares Stockists—continued

Town	Name of Stockist	Address	Telephone No.	Telegraphic Address
Wakefield	Parkinsons (Wakefield) Ltd.	38-40 Ings Road	2087	
Walsall	The Motor Cycle Mart (Walsall) Ltd.	12 Ablewell Street	3363	
Warrington	Jack Frodsham Ltd.	37a Winwick Street	34713	
Watford	Lloyd Cooper & Co.	61 Queen's Road	2125	Lloyd Cooper, Watford
Westcliff-on-Sea	J. Costin & Sons	233-5-7 London Road	Southend 42215	
Weston-super-Mare	Wyvern's of Weston Ltd.	3 Locking Road	524	Wyvern's, Weston-super-Mare.
Weybridge	W. L. Lewis & Sons	51 Church Street	2210	
Weymouth	Tilleys	9 Frederick Place	72	
Whitehaven	Mark Taylor	21 King's Street	252	
Wolverhampton	C. E. Cope & Sons Ltd.	168-9 Stafford Street	24605/6	
Worcester	W. J. Bladder & Son	52 Sidbury	2438	Bladder, Sidbury, Worcester.
Worksop	Ezra Sugden Ltd.	109 Gateford Road	3053	
Yeovil	The Yeovil Motor Mart	Hendford	267	Motor Mart, Yeovil
York	C. S. Russell (York) Ltd.	Lawrence Street	23793	Russell, Lawrence Street, York.

PROPRIETARY INSTRUMENTS FITTINGS AND ACCESSORIES

No expense is spared to secure as standard equipment the most suitable and highest quality instruments and accessories. Nevertheless, the Company's guarantee does not cover such parts, and in the event of trouble being experienced the parts in question should be returned to and claims made direct on the actual manufacturers, who will deal with them on the terms of their respective guarantees, as follows:

Carburettors: Messrs. Amal Ltd., Holford Works, Perry Barr, Birmingham.

Dual Seats: Motoplas Co. Ltd., Armoury Road, Birmingham 11.

Electrical Equipment: Messrs. Joseph Lucas Ltd., Birmingham.

Spring Seat Saddles: Messrs. Herbert Terry & Sons Ltd., 210 Corporation Street, Birmingham.

Speedometers and Rev. Counters: Messrs. Smiths Motor Accessories Ltd., Cricklewood, London, N.W.2.

Tyres: Messrs. Dunlop Rubber Co. Ltd., Fort Dunlop, Birmingham.

Rear Suspension Units: Girling Ltd., Kings Road, Birmingham 11.

SPECIAL NOTE

Claims under guarantee, whether to B.S.A. Motor Cycles Ltd., or any of the manufacturers listed above, should be submitted through the B.S.A. Dealer from whom the machine was purchased.